

Premier *Quatro*

MKII PROTOCOL - ONE TO FOUR LOOPS ANALOGUE ADDRESSABLE FIRE ALARM PANEL



INSTALLATION MANUAL



Manual Sections

1- SAFETY INFORMATION.....	4
1.1 INSTALLATION INFORMATION.....	4
1.2 SAFETY PRECAUTIONS DURING NORMAL OPERATION OF PANEL.....	4
1.3 BATTERY INFORMATION.....	4
1.4 PRODUCT DISPOSAL AT THE END OF IT'S WORKING LIFE.....	4
1.5 USING THIS MANUAL.....	4
1.6 FIRE ALARM SYSTEMS CODE OF PRACTICE.....	5
1.7 EQUIPMENT WARRANTY.....	5
2- PANEL SPECIFICATION.....	5
2.1 FUNCTIONS REQUIRED BY EUROPEAN STANDARD EN-54 PART 2.....	5
2.2 EXPLANATION OF ACCESS LEVELS.....	6
2.3 PANEL SPECIFICATION – ENCLOSURE.....	6
2.4 PANEL SPECIFICATION – ELECTRICAL.....	7
2.5 FUSE SPECIFICATIONS - POWER SUPPLY CONTROLLER PCB.....	8
2.6 FUSE SPECIFICATIONS – CIE TERMINATION PCB.....	9
3- INTRODUCTION TO THE QUATRO PANEL.....	10
3.1 ABOUT THE PREMIER QUATRO FIRE ALARM PANEL.....	10
3.2 PANEL INTERNAL LAYOUT.....	10
3.3 NAVIGATING THE PANEL MENUS.....	11
3.3.1 NAVIGATING A SET-UP SCREEN.....	11
3.4 CONTROLS.....	11
3.5 INDICATING DIFFERENT PANEL STATES.....	12
3.5.1 THE QUIESCENT CONDITION.....	12
3.5.2 THE ALARM CONDITION.....	12
3.5.3 THE FAULT CONDITION.....	13
3.5.4 DISABLEMENT.....	13
3.5.5 TEST MODE.....	13
4- DESIGNING THE SYSTEM.....	14
4.1 DESIGNING THE SYSTEM.....	14
4.2 RECOMMENDED CABLE TYPES AND THEIR LIMITATIONS.....	14
4.3 LOOP CALCULATIONS.....	14
4.4 MAXIMUM LOOP CABLE LENGTH RECOMMENDATIONS.....	15
4.5 BATTERY CALCULATIONS.....	15
4.6 CHOOSING AUDIBLE AND VISUAL WARNING DEVICES.....	15
4.6.1 ADDRESSABLE STAND-ALONE SOUNDERS.....	15
4.6.2 SOUNDER BASE (SANDWICH SOUNDER – REMOTE LED MODE).....	15
4.6.3 SOUNDER BASE (SANDWICH SOUNDER - ADDRESSED MODE).....	15
4.6.4 ADDRESSABLE SOUNDER CIRCUIT CONTROLLER.....	16
4.6.5 PCB CONVENTIONAL SOUNDER CIRCUITS.....	16
4.6.6 EVACS 16 VOICE ALARM SYSTEM.....	16
4.6.7 ADVANTAGES AND DISADVANTAGES OF DIFFERENT SOUNDER TYPES.....	16
4.7 SYSTEM SPARE CAPACITY.....	16
4.8 PRE COMMISSIONING CHECKS LIST.....	17
5- MOUNTING THE FIRE ALARM CONTROL PANEL.....	18

5.1 LOCATING THE FIRE ALARM CONTROL PANEL.....	18
5.2 FIXING THE BACK BOX TO THE WALL.....	18
5.3 MAINS WIRING RECOMMENDATIONS.....	19
5.4 PLANNING CABLE ENTRY.....	19
5.5 CONNECTING THE MAINS POWER.....	19
5.6 CONNECTING THE BATTERY.....	20
6- INSTALLING THE DEVICES.....	21
6.1 ADDRESSABLE LOOP WIRING.....	21
6.2 ADDRESSABLE LOOPS (PRE-COMMISSIONING CHECK).....	21
6.3 SPECIFIC DEVICE WIRING INSTRUCTIONS.....	22
6.3.1 CP3/AD MANUAL CALL POINT.....	22
6.3.2 MKII DETECTORS.....	22
6.3.3 ZAI-MI INPUT MODULE.....	23
6.3.4 ZAIO-MI INPUT/OUTPUT MODULE.....	23
6.3.5 ZASC-MI SOUNDER CONTROL MODULE.....	24
6.3.6 ZAZM-MI CONVENTIONAL ZONE MODULE.....	24
6.3.7 XTRATONE SOUNDER/SOUNDER FLASHER.....	25
6.3.8 SANDWICH SOUNDER.....	25
6.3.9 REMOTE LED INDICATOR.....	26
6.4 SETTING THE DEVICE ADDRESS (DETECTORS, CALL POINTS, SOUNDERS AND INTERFACE UNITS).....	27
6.4.1 SOFT AND HARD PROGRAMMING.....	27
6.4.2 DIP SWITCH ADDRESS SETTINGS – FULL TABLE.....	27
6.5 FIRE RELAY (VOLTAGE FREE CHARGE OVER CONTACTS).....	29
6.6 FAULT RELAY (VOLTAGE FREE CHANGE OVER CONTACTS).....	30
6.7 AUXILIARY DC OUTPUT.....	30
6.8 FIELD DEVICE TERMINATION.....	30
7- PANEL SETUP.....	30
7.1 INITIAL PANEL SETUP.....	30
7.1.2 POWER SUPPLY.....	31
7.1.3 LOOP MANAGEMENT.....	31
7.1.4 SETTING TIME AND DATE.....	31
7.1.5 CREATING AN INSTALLATION NAME.....	31
7.1.6 PASSWORDS.....	31
7.1.7 LED FLASH SETUP.....	32
7.1.8 ENGINEERING.....	32
7.1.9 ENABLE USB CONFIG.....	32
7.1.10 PRINTER SETUP.....	32
7.1.11 ALARM TONE SETUP.....	33
7.1.12 FLASHER OPERATION.....	33
7.1.13 CONFIGURING THE LOOPS.....	33
7.1.14 ZONE LABELS.....	34
7.1.15 ADDRESS LABELS AND ZONES.....	34
7.1.16 PLATFORM SOUNDER (SANDWICH SOUNDER).....	34
7.1.17 VIEWING DEVICE STATUS.....	35
7.1.18 LOCATE OR VERIFY A DEVICE.....	35
8- NETWORKING.....	35
8.1 NETWORKING INTRODUCTION.....	35

8.2 RING NETWORK.....	35
8.3 BUS NETWORK.....	35
8.4 CONFIGURING THE NETWORK.....	36
8.5 MODBUS.....	37
8.6 REPEATER PANEL.....	38
9- PROGRAMMING.....	39
9.1 CAUSE AND EFFECT.....	39
9.1.1 ACTIONS.....	39
9.1.2 LOGIC.....	40
9.1.3 CLASS CHANGE.....	41
9.1.4 DISABLE RELAYS.....	41
9.1.5 DISABLE OUTPUTS.....	41
9.1.6 DAY & NIGHT MODE.....	41
9.1.7 OUTPUTS AND DELAYS.....	41
9.2 CONFIGURATION SOFTWARE.....	42
10- MENU COMMAND STRUCTURE.....	44
10.1 USER LEVEL (LEVEL 1).....	44
10.2 INSTALLER LEVEL (LEVEL 2).....	45
10.3 CAUSE & EFFECT TABLE.....	46
11- DISABLEMENTS.....	47
11.1 DISABLEMENT.....	47
11.2 ZONE DISABLEMENT.....	47
11.3 DEVICE DISABLEMENT.....	48
11.4 SOUNDER DISABLEMENT.....	48
11.5 RELAY DISABLEMENT.....	49
11.6 DISABLE BUZZER.....	49
12- TEST MODE.....	49
12.1 WHY USE TEST MODE.....	49
12.2 TO PROGRAMME ZONE IN TEST MODE.....	49
13- FAULT FINDING.....	50
13.1 LOOP CONTENTS FAULT FINDING.....	50
13.2 ZONE FAULTS.....	50
13.3 FALSE ALARMS.....	51
13.4 SUPPLY FAULTS.....	51
13.5 EARTH FAULTS.....	52
13.6 SYSTEM FAULT.....	52
13.7 SOUNDER FAULTS.....	52
13.8 OUT OF SERVICE FAULTS.....	52
13.9 NETWORK FAULTS.....	52
14- EVENT LOGS.....	52
15- STANDBY BATTERY REQUIREMENTS.....	54
15.1 PANEL & DEVICE CURRENT RATINGS.....	54
15.2 STANDBY BATTERY CALCULATION.....	55
16- QUATRO PANELS AVAILABLE.....	56

1- SAFETY INFORMATION

WARNING: Read this section completely before commencing installation.

1.1 INSTALLATION INFORMATION

THIS FIRE ALARM CONTROL PANEL IS CLASS 1 EQUIPMENT AND MUST BE EARTHED.

This equipment must be installed and maintained by a qualified and technically experienced person.

This C.I.E (control & indicating equipment) must be wired to a fused spur rated at 3A. It must NOT be connected via a removable plug, or be connected through an RCD device.

Prior to commencing installation of the control panel, ensure that adequate precautions are taken to prevent damage to the sensitive electronic components on the display board and the control board due to electrostatic discharge. You should discharge any static electricity you may have accumulated by touching a convenient earthed object such as an unpainted copper radiator pipe. You should repeat the process at regular intervals during the installation process, especially if you are required to walk over carpets.

The panel must be located in a clean, dry position, which is not subject to excessive shock or vibration and at least 2 metres away from pager systems or any other radio transmitting equipment. The operating temperature range is 0°C to 40°C; maximum humidity is 95%.

HANDLING THE PCBs - If the PCBs are to be removed to ease fitting the enclosure and cables, care must be taken to avoid damage by static.

The best method is to wear an earth strap, but touching any earth point (e.g. building plumbing) will help to discharge any static. Always handle PCBs by their sides and avoid touching the legs of any components. Keep the PCBs wrapped in anti-static protective bubble wrap and away from damp dirty areas, e.g. in a small cardboard box.

1.2 SAFETY PRECAUTIONS DURING NORMAL OPERATION OF PANEL

NOTE: When the Quatro panel is operating normally, i.e. not being tended by service personnel, the access door must be closed and locked. After locking, the key **MUST** be removed and **ONLY** held by the responsible person and / or the service personnel. It must under **NO CIRCUMSTANCES** be held by the user.

1.3 BATTERY INFORMATION

This C.I.E (control & indicating equipment) uses 2 x 12V Sealed Lead Acid (SLA) batteries with capacities between 7Ah and 17Ah.

CAUTION:

THERE IS A RISK OF EXPLOSION IF BATTERY IS REPLACED BY AN INCORRECT TYPE. DISPOSE OF USED BATTERIES ACCORDING TO BATTERY MANUFACTURERS INSTRUCTIONS.

IMPORTANT NOTES ON BATTERIES:

DANGER: Batteries are electrically live at all times. **NEVER short circuit the battery terminals.**

WARNING: Batteries are often heavy. Each 17Ah battery weighs 6.1kg. Take great care when lifting and transporting batteries.

DANGER: Do NOT attempt to remove the battery lid or tamper with the internal workings of the battery. Electrolyte is a highly corrosive substance, and presents significant danger to you and to anything else it touches. In case of accidental skin or eye contact, flush the affected area with plenty of clean, fresh water and seek immediate medical attention. Valve Regulated Lead Acid (VRLA) batteries are "low maintenance", requiring no electrolyte top-up or measurement of specific gravity.

1.4 PRODUCT DISPOSAL AT THE END OF ITS WORKING LIFE

Like all electronic equipment, at the end of its working life this unit should not be disposed of in a refuse bin. It should be taken to a local reprocessing site as per the guidelines of the WEEE directive, for correct disposal.

1.5 USING THIS MANUAL

This manual explains, in a step-by-step manner, the procedure for the installation of the Premier Quatro Fire Alarm Control Panel. This Installation Manual must not be left accessible to the User.

1.6 FIRE ALARM SYSTEMS CODE OF PRACTICE

This manual is not designed to teach Fire Alarm System design. It is assumed that the System has been designed by a competent person, and that the installer has an understanding of Fire Alarm System components and their use.

We strongly recommend consultation with a suitably qualified, competent person regarding the design of the Fire Alarm System.

The System must be commissioned and serviced in accordance with our instructions and the relevant National Standards. Contact the Fire Officer concerned with the property at an early stage in case he has any special requirements.

If in doubt, read BS 5839-1:2013 "Fire Detection and Alarm Systems for buildings (Code of Practice for System Design, Installation, commissioning and maintenance)" available from the BSI, or at your local reference library.

1.7 EQUIPMENT WARRANTY

If this equipment is not fitted and commissioned according to our guidelines, and the relevant National Standards, by an approved and competent person or organization, the warranty may become void.

2- PANEL SPECIFICATION

2.1 FUNCTIONS REQUIRED BY EUROPEAN STANDARD EN54 PART 2

The Premier Quatro fire alarm control panel provides the following mandatory and optional functions as prescribed by the European standard EN54 Part 2.

(a) Mandatory Functions

The mandatory functions and corresponding indications provided by this panel are:

- fire alarm
- fault warning
- disabled
- quiescent (when the CIE is powered by a power supply conforming to EN54-4 and no other functional condition is indicated)

(b) Optional Functions (Options with Requirements)

The options with requirements provided by this panel are:

- Clause 7.8 - output to fire alarm devices (i.e. sounders)
- Clause 7.11 - delays to outputs
- Clause 8.3 - fault signals from points
- Clause 9.5 - disablement of addressable points
- Clause 10 – test Condition

(c) Other Functions outside EN54

RS232 Serial Output (Printer / Pager)

RS484 Network / Repeater connection

RS485 Modbus connection

TCP/IP (Ethernet) connection (Data log Alarm Manager)

NB the terms 'device' and 'point' are used interchangeably throughout this manual.

2.2 EXPLANATION OF ACCESS LEVELS

The Premier Quatro System has the following access levels.

ACCESS LEVEL	ACCESSED BY	ACCESS METHOD	FUNCTIONS ACCESSED
1	General public	Default state	View Panel Override delay (if used)
2a	Responsible person	Key switch to ON	Start/stop sounders Silence buzzer Reset panel
2b	Responsible person	Key switch ON & user password	Enable / disable sections of system Test Mode View Zones / Points View event log Turn off delay
3a	Installer / Engineer	Key switch ON & Installer password	Configure loops Assign zones Assign Text to each point Modify Alarm Operation Programming Configure network (if fitted) System Diagnostics (LED blink / loop Auto check) Change passwords Configure RS232 Output (if fitted)
3b	Installer / Engineer	Open Enclosure Lock	Connect wiring during Install Battery check during Maintenance Reset System fault Update Cause & Effect programming via USB
4	Authorised Service Engineer	Open Enclosure Lock & PC Programming Software	Configure Panel protocol

Care should be taken to ensure that the access method for each level is only available to suitably qualified personnel.

2.3 PANEL SPECIFICATIONS - ENCLOSURE

DESCRIPTION	VALUE
ENCLOSURE SIZE (L x W x D mm)	485 x 477.5 x 125
TOP CABLE ENTRIES	20
BOTTOM CABLE ENTRIES	6

2.4 PANEL SPECIFICATIONS - ELECTRICAL

ELECTRICAL DESCRIPTION	VALUE
MAINS VOLTAGE	230 V AC + 10% / - 15%
BATTERY VOLTAGE	2 x 12V SLA (27.6V DC @ 20 C) (7Ah – 17Ah)
POWER SUPPLY	NON-INTEGRAL (SWITCH MODE) DC OUTPUT: Vmax = 31V ,Vmin = 19V I max A: 4.1 A Ripple & Noise: <= 0.6V
CIE DC INPUT VOLTAGE	Vmax = 31.5V, Vmin = 19V
CHARGER VOLTAGE	27.6V
CONVENTIONAL SOUNDER OUTPUT (x2)	I max: 450mA Quiescent voltage: 5 to 9V DC Active voltage: 18 to 28V DC End-of-Line Resistance: 4k7 ohm 0.25W
FIRE RELAY OUTPUT (x1)	(C,NO,NC) Contact rating: 30V DC @ 1A
FAULT RELAY OUTPUT (x1)	Normally Energized (C,NO,NC) Contact rating: 30V DC @ 1A
LOOP VOLTAGE	Vmax 32 V DC Vmin 26 V DC
MAXIMUM LOOP CURRENT	500 mA
NUMBER OF LOOPS	4
MAXIMUM NUMBER OF ZONES	250 Zones
MAXIMUM LOOP CAPACITY	250 Addresses
MAXIMUM LOOP LENGTH	2 km
MAXIMUM LOOP RESISTANCE	44 ohm (22 ohms + to +, 22 ohms – to -)
MAXIMUM LOOP CAPACITANCE	500nF
MAXIMUM LOOP BAUD RATE	1024 Bits Per Second
MAXIMUM NETWORK SIZE	32 nodes
MAXIMUM DISTANCE BETWEEN NODES	1 km
CABLE TYPE	Fire Proof 2 core + screen 1.5 mm ²
ALPHA NUMERIC (LCD) DISPLAY	40 x 4 characters
LED INDICATIONS	Fire (Zones 1 – 20) Fault / Disable / Test (Zones 1 – 20)
KEY ENTRY	12 alphanumeric 6 navigational 3 mandatory 4 menu functions (F1, F2, F3, F4)
ENVIRONMENTAL DATA	Temperature: -5 to 40 C Relative Humidity: 95% Non-Condensing will withstand vibrations between 5 & 150 Hz
ENCLOSURE RATING	IP 30
OTHER PORTS	USB RS485 via plug in network card RS232 via plug in network card TCP/IP via plug in network card
EN54-2 Optional Functions with Requirements	7.8, 7.11, 8.3, 9.5, 10

2.5 FUSE SPECIFICATIONS - Power Supply Controller PCB

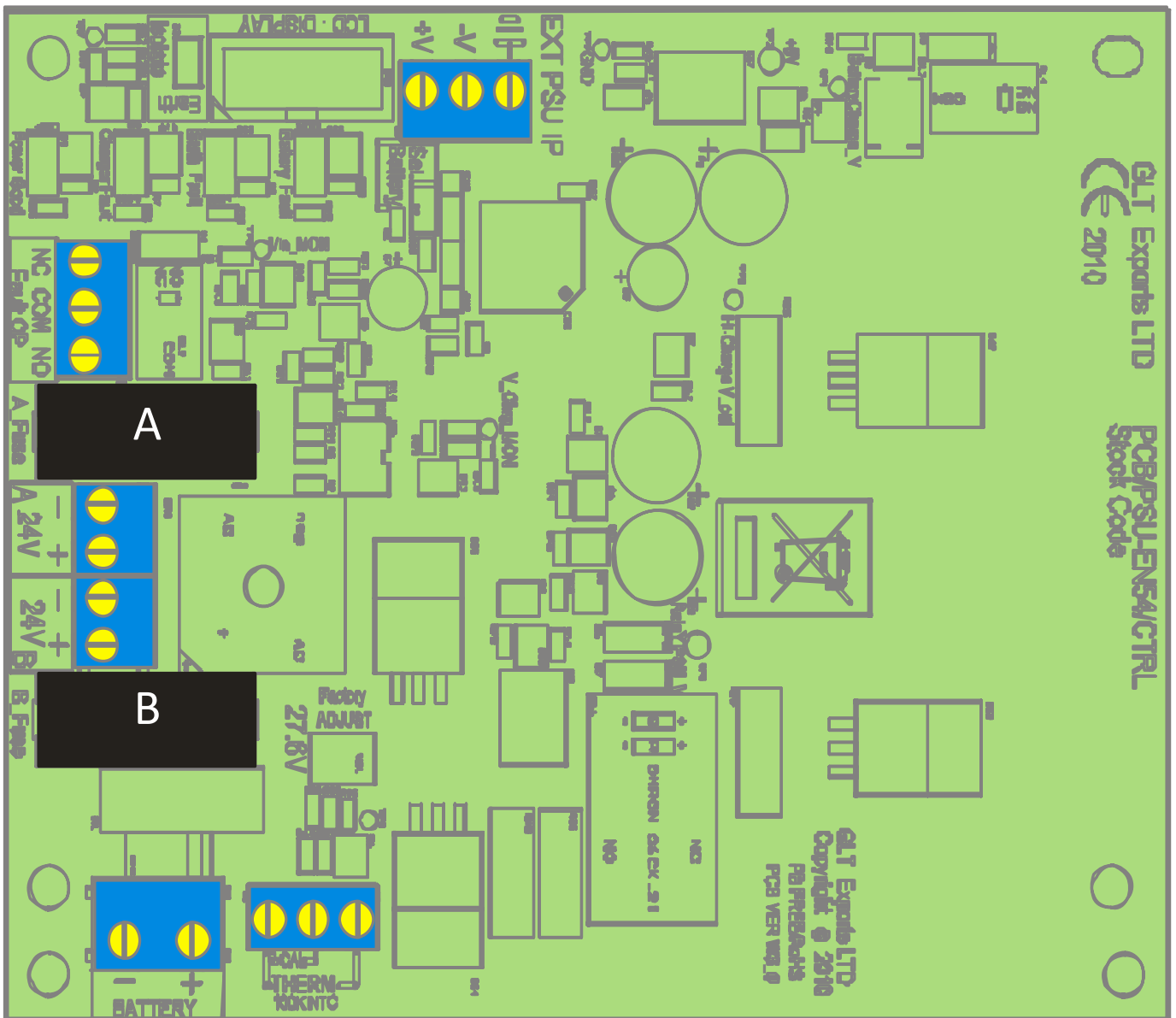

Fuse Label	Rating	Description
A_Fuse	2.5A	PSU Output – Channel A
B_Fuse	2.5A	PSU Output – Channel B
Link Fuse	8A	Battery fuse

2.6 FUSE SPECIFICATIONS - CIE Termination PCB

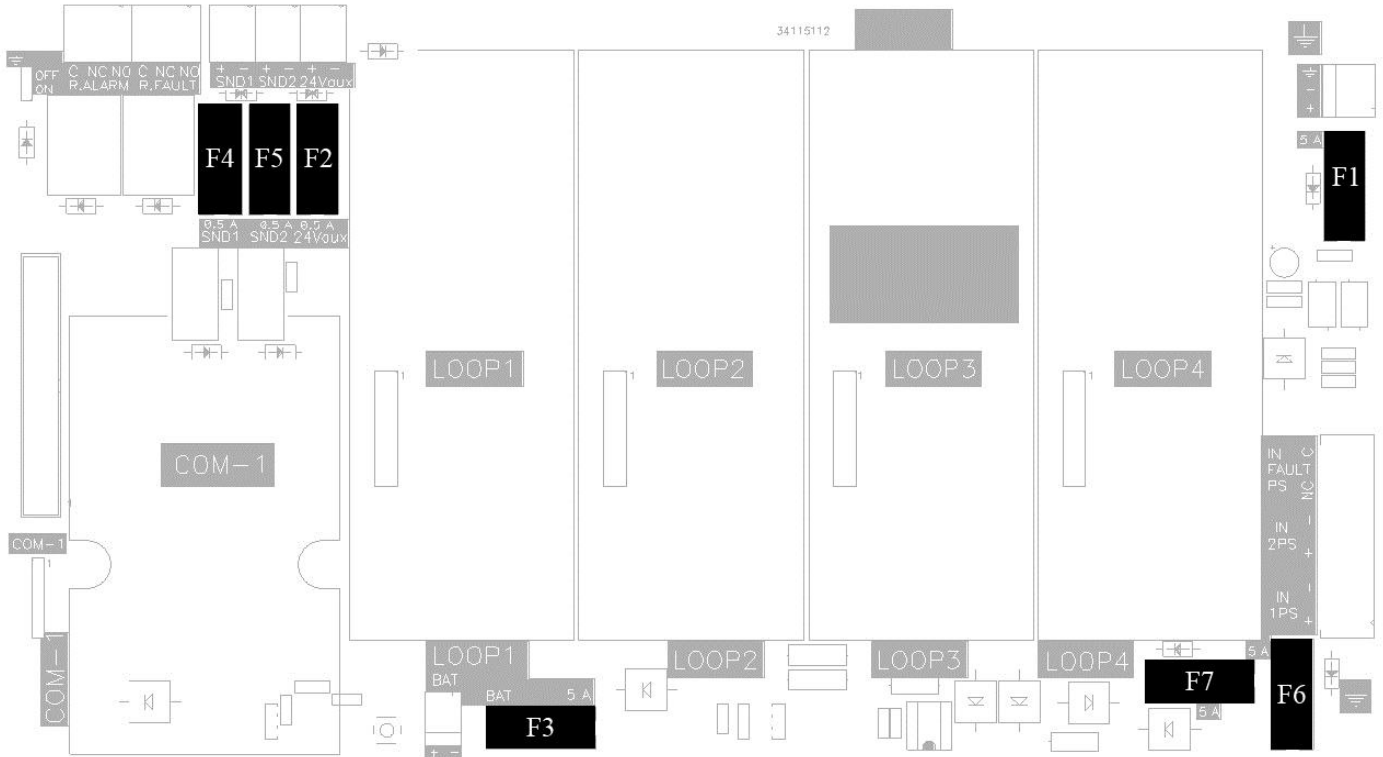

Fuse	Rating	Description
F1	NOT USED	NOT USED
F2	F 500 mA	24V Aux Supply Fuse
F3	NOT USED	NOT USED
F4	F 500 mA	Conventional Sounder Circuit SND 1
F5	F 500 mA	Conventional Sounder Circuit SND 2
F6	F 5 A	IN PS1 Fuse – Power from PSU Controller
F7	F 5 A	IN PS2 Fuse – Power from PSU Controller

(Fuses 1 & 3 are used for the “Motherboard Charger” option)

3- INTRODUCTION TO THE QUATRO PANEL

3.1 ABOUT THE PREMIER QUATRO FIRE ALARM PANEL

- The Premier Quatro is a 1 to 4 loop Analogue addressable control panel that uses the Zeta Fyreve MKII Protocol.
- It has a 4 x 40 character LCD Display.
- It can run up to 250 devices per loop.
- It has 250 zones, with 20 (as standard), or 120 zones (with LED expansion card) indicated by LED.
- It is available with an optional built in panel printer
- It can be networked with other Quatro panels (or repeaters) with up to 32 panels per network.
- It has a simple Intuitive Action Programming for configuring sounder & relay operations.
- It has an optional add on TCP-IP card that allows the panels recent events to be viewed in a web browser.
- It has an advanced Alarm management graphics package (works with TCP-IP card).
- It has an easy to use configuration software package which makes setting up cause and effects straightforward.
- It has useful loop inspector software that enables users to check the health & analogue values of devices connected to the panel.

3.2 PANEL INTERNAL LAYOUT

Figure 1: Plan view of Quatro panel showing internal view of populated enclosure on the right & inside of hinged door on the left.

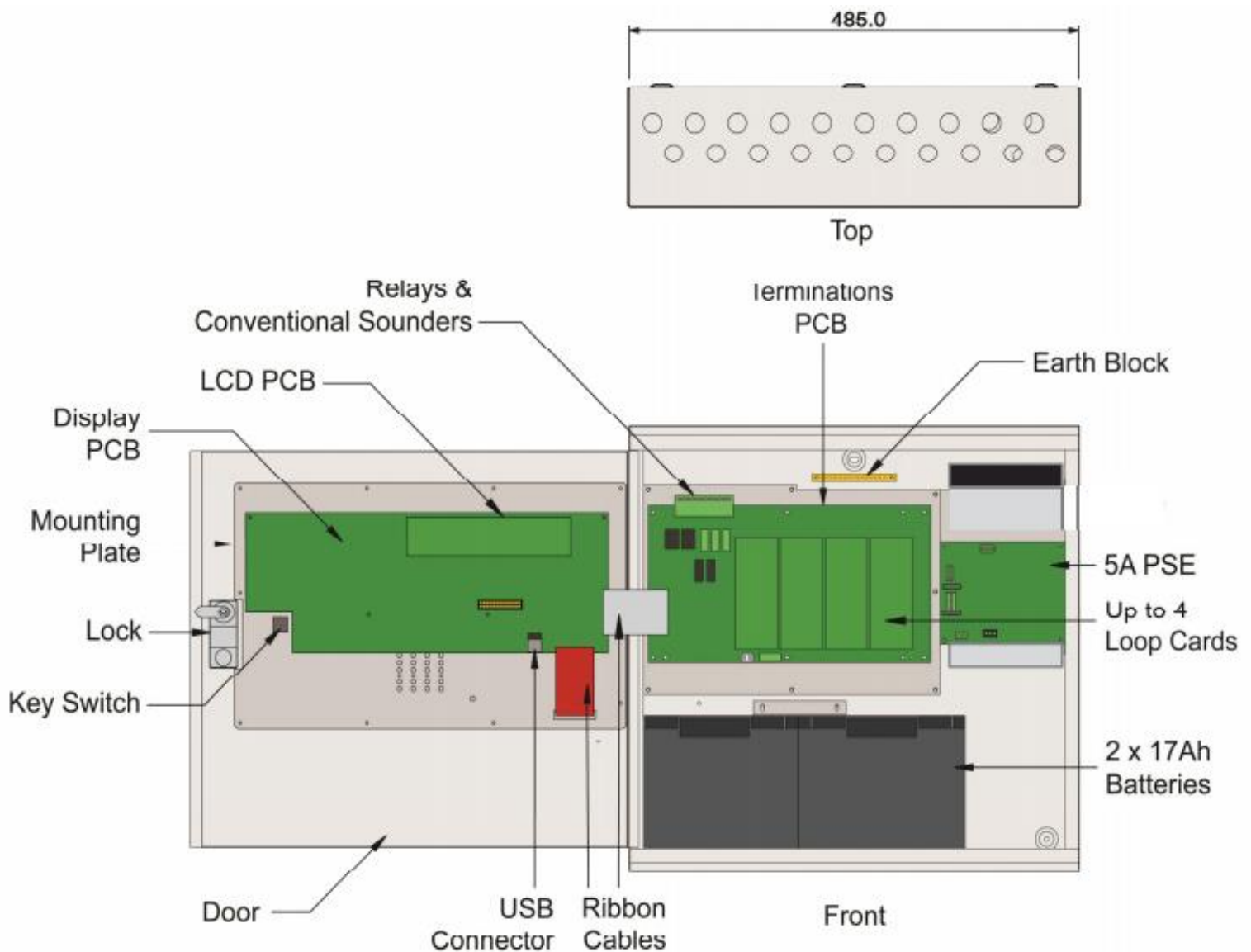

3.3 NAVIGATING THE PANEL MENU

The Quatro panel has 2 menus, user and installer. Entering the user code (Default 1111) accesses the user menu and entering the Installer password (Default 2222) accesses the Installer menu.

The Left hand side of the screen shows the list of options. The up & down arrows on the cursor pad are used to move between options. The Currently selected option is shown with an asterisk. If an option has a right facing arrow, it means that option has a sub menu that will be displayed on the right hand side of the screen if selected.

The center dividing line may have an arrow at the top or bottom of the screen. This means that you can move the asterisk cursor in the indicated direction.

On the sub menu, there is also the asterisk and top/bottom arrow's to show the highlighted option and the scroll directions.

To enter a sub-menu, press the right cursor.

To select an item press the accept (Tick) button

To leave the sub menu press the left cursor

3.3.1 Navigating a set-up screen.

The Premier Quatro has several configuration screens. They all work in generally the same way

The Highlighted field is shown as <xxxxxxx>

A non-highlighted field is shown as [xxxxx]

Left & right cursors are used to move between fields

Up and down cursors are used to cycle values in the fields.

Numeric fields can have the value entered directly (with leading zeros if necessary)

Text fields Use up & down cursors to move the cursor in the string.

3.4 CONTROLS

The panel contains the following mandatory controls. They can only be operated when the key on the front of the panel has been turned clockwise from OFF to CONTROLS ENABLED. The CONTROLS ACTIVE LED indicates that the controls have been enabled.

START / STOP SOUNDERS

This control can be used by authorised personnel to stop or silence the sounders whilst the panel is in the fire alarm condition. This control will alternately stop and start the sounders (i.e. silence and sound the alarms).

SILENCE BUZZER

This control silences the panel's internal buzzer which is always activated when a fire or a fault has been detected.

RESET

After a fire or false alarm has been fully investigated and dealt with, operating this control resets the fire alarm condition. The same control is used to reset from a fault condition.

It is good practice to stop the sounders before resetting the panel. However, pressing the RESET control whilst the sounders are still active will silence the sounders as well as resetting the fire alarm condition (although it is recommended that you always silence the sounders via the 'stop sounders' button before resetting the panel).

OTHER CONTROLS

In addition to the 3 mandatory controls, the keypad also provides:

12 alphanumeric (including ENTER and CANCEL), 6 navigational (▲, ▼, ◀, ▶, ✓, ✕) and 4 menu functions (F1, F2, F3, F4) keys.

Each menu function key corresponds to the function or command label in square brackets which is displayed on the bottom line of the LCD immediately above the function key.

3.5 INDICATING DIFFERENT PANEL STATES

During Normal operation the panel will be in one of the following states depending on the status of the devices connected to the panel, and user intervention. Below is a summary of the different conditions

3.5.1 The Quiescent Condition

This is the panels' normal state. There are no faults or alarms, and the panel is running normally. This is indicated by The LCD showing System Normal, and All LEDs being off, apart from Power, and perhaps Controls Active (depending on the position of the key switch.

In the quiescent condition, the panel displays:-

Panel/site name (if entered), Time & date, System Normal Message, and Zeta MKII Panel for a Fyreve MKII Protocol system.

```
Panel/site name      10/12/13 13:30
                    SYSTEM NORMAL
                    ZETA MARKII 4 LOOP PANEL
```

Note: The number of loop cards are installed inside the panel will be reflected on the System Normal message.

3.5.2 The Alarm Condition

A fire is indicated on the Quatro panel by the COMMON FIRE red LED (A steady LED represents a Call Point Alarm, and a flashing LED represents a Detector Alarm). The zonal location of the fire is indicated by one of the zonal indication red LEDs. Zonal indication is limited to the first 20 (or 120 with a 100 Zone LED expansion card) zones of the installation. Fires in all zones will be indicated on the LCD. An example of the 4 line fire display is shown below:

First Zone in Alarm

Line 1 indicates the first zone in fire. In the example, the first alarm was in Zone 3. Zone 3 is the Second Floor.

```
FIRST ALARM: Z003 - SECOND FLOOR
LAST ALARM : Z005 - FOURTH FLOOR
ZONES IN FIRE:004 POINTS IN FIRE:010
PRESS ◀ OR ▶ TO SCROLL
```

The 2nd line indicates the most recent zone in fire. The format is the same as line 1. The most recent fire occurred in Zone 5, which is the Fourth Floor.

Two or more zones in alarm

Line 1 indicates the first zone in fire. In the example, the first alarm was in Zone 3. Zone 3 is the Second Floor.

```
FIRST ALARM: Z003 - SECOND FLOOR
LAST ALARM : Z005 - FOURTH FLOOR
ZONES IN FIRE:004 POINTS IN FIRE:010
PRESS ◀ OR ▶ TO SCROLL
```

The 2nd line indicates the most recent zone in fire. The format is the same as line 1. The most recent fire occurred in Zone 5, which is the Fourth Floor.

Line 3 shows the total number of zones in fire and the total number of points / devices in fire.

All the points that are in the fire condition can be displayed in turn by using the ◀ or ▶ keys to scroll through the fires. This information is displayed on lines 3 and 4. For example:

In this example, line 3 indicates the 2nd point of the 10 points in fire. Point 2 was triggered at the time 08:10. Point 2 is in Zone 17 (the Stair Well). Point 2 is an Optical detector connected to Panel 2 and Loop 4. Its address is 124.

```
FIRST ALARM: Z003 - SECOND FLOOR
LAST ALARM : Z005 - FOURTH FLOOR
002/010-08:10 Z017 - STAIR WELL
MKII-AOP (2.4.124) - ROOM 101
```

Note that if the device in alarm is connected to one of the loops of the panel which is indicating the fire, the panel number is not displayed in line 4, i.e. MKII-AOP (4.124 - ROOM 101).

3.5.3 The Fault Condition

All faults are indicated by a flashing yellow common fault LED, and either an additional fault LED, or an LCD message.

Faults can be divided into 2 types, "Faults" and "Device Faults". Device Faults are any fault associated with a particular address on the loop. Faults are everything else, e.g. sounder circuits, power supply etc. Any fault on the panel will flash the common fault LED in addition to displaying details of the fault. Some examples are shown below:-

In this example, the MKII-AOH detector at loop 1 address 6 had been removed. It is shown as the first fault on the system (Fault 0001/0001), and the time & date of the event are logged.

```

FAULT      0001/0001    10/12/13 13:51
MKII-AOH   (1.006)    REMOVED
TEXT      : Reception Opposite Stairway
    
```

In this example, there is a short circuit fault on the on board sounder circuit two.

```

FAULT      0001/0001    10/12/13 13:51
Short Fault      SOUNDER TWO
    
```

3.5.4. Disablement

To aid commissioning and assist routine maintenance checks, various functions of the Quatro fire alarm system can be disabled as described in the disablements section later in the manual.

Disablements are indicated with the general disablement LED, and a mixture of LCD/LED indications. Examples are:-

In this example, zone 1 is disabled. It is the only disablement (001/001). Zone 1 fault/test/disable LED and the general disablement LEDs are lit steady

```

                                     10/12/13 13:51
DISABLED ZONES                        001/001
Z001 - Ground Floor
[ - ] [ + ]
    
```

In this example, the addressable point at loop 1 address 1 is disabled. It is a call point. General disablement LED is lit. Zone is not lit because the whole zone is not disabled

```

                                     10/12/13 13:51
DISABLED POINTS                       001/001
MCP (1.001) Front Door
[ - ] [ + ]
    
```

In this example, sounder circuit 1 on the motherboard has been disabled

```

                                     10/12/13 13:51
DISABLED PCB SOUNDER                 001/001
SOUNDER ONE
[ - ] [ + ]
    
```

3.5.5. Test Mode

To aid commissioning and assist routine maintenance check, a non-latching 'one man test' facility is available.

When a detector, manual call point or input unit is triggered on any zone in Test, the Alarm sounders operate for approximately 10 seconds on and then switch off. The triggered device is automatically reset. The panel will enter the fire condition and indicate the address of the fire. The panel automatically resets from the fire condition at the same time as the triggered device, but the LCD indication remains until the panel is manually reset.

If the device is still in the fire condition, e.g. MCP still activated or the analogue value of a detector still above the alarm threshold, the device will be triggered again and the Alarm sounders will operate for a further 10 seconds.

If an Alarm occurs on a zone that is not programmed to test, the Fire Alarm Panel will continue to operate as normal.

In this example, zone 1 is in test mode. It is the only zone in test mode (001/001). Zone 1 fault/test/disable LED and the general test LEDs are lit and are steady.

```

                                     10/12/13 13:51
ZONES IN TEST                        001/001
Z001 - Ground Floor
[ - ] [ + ]
    
```

4 - DESIGNING THE SYSTEM

4.1 DESIGNING THE SYSTEM

The first consideration when designing the fire alarm system is the type or category of fire protection that is required for the building. In the UK this is fully explained in the British Standard BS 5839-1:2013. This contains guidance on how many smoke detectors, heat detectors, call points, sounders etc. should be fitted for the type of coverage that is required.

Next decide on the number of loops of addressable devices that need to be installed. Quatro can be fitted with 1 to 4 loops. The maximum loop capacity is 250 devices (also called points or addresses), but do not exceed the 500mA maximum loop current. If the building requires more than 4 x 250 devices, then the control panels can be networked. The network capacity is 32 panels (including repeater panels or LED Driver's if required).

All fire alarm systems must be subdivided into zones, which represent the geographical areas of the building. Quatro allows any number of devices to be allocated to a zone. However, it is assumed that a zone will not contain more than 32 fire detectors and/or manual call points, since this would correspond to an unacceptably large search area.

Each panel may be configured to have between 1 and 250 zones.

Although a fire alarm system has to be subdivided into zones, the cause and effect actions applicable to Quatro can be based on other groupings as well as zones. The other groupings are panels, loops and points. Cause and effect is described in the Section 9.1.

In order to gain the maximum benefits from Quatro, it is worth considering the types of sounder that can be connected to the system before getting to the cause and effect configuration stage. These sounders and their respective advantages / disadvantages are explained in Section 4.6.7.

Whenever possible, give each device as descriptive a label as possible. The better the description, the easier it is to locate in the event of an alarm. The panel allows 22 characters. It may be necessary to use abbreviations to achieve the required label. Keep the design of the system, and any changes to it well documented. This makes it easier to trace any configuration errors during installation & commissioning.

4.2 RECOMMENDED CABLE TYPES AND THEIR LIMITATIONS

The use of Mineral Insulated Cable is not recommended on the Premier Quatro.

All wiring must be installed to meet BS 5839-1:2013 and BS 7671:2008 (IEE Wiring Regulations) standards. Other National standards of fire alarm system installation should be adhered to where applicable.

Screened cables should be used throughout the installation to help shield the Panel from outside interference and ensure EMC compatibility.

The two categories of cable according to BS 5839-1:2013, Clause 26 "Fire Detection and Alarm Systems for Buildings (Code of Practice for System Design, Installation and Servicing)" are:

Standard fire resisting cable – to PH30 classification of EN50200 (including the 30 minute survival time of Annex E)

Enhanced fire resisting cable – to PH120 classification of EN50200 (including the 120 minute survival time of BS 8434-2)
(Note that all cables should be at least 1mm² cross section)

On the Premier Quatro Panel the general recommendation would be to use standard fire resistant cable, such as GLT Exports Fire Defence Cable, Firetuff™, FP200 or an equivalent. These cables are screened, and will provide good EMC shielding when properly grounded at the panel. Certain system specifications may demand the use of a particular type of cable and due regard should be paid to this fact. For non-BS5839 installations, other cable types may be suitable.

Depending on the environment, the cables may need mechanical protection (such as a conduit).

4.3 LOOP CALCULATIONS

Like most addressable systems, it is important that a system is designed within the panel's limits. The following Limits should not be exceeded:-

Characteristic	Limit
Maximum loop load	500mA
Maximum Quiescent loop load	400mA
Maximum cable resistance	22 ohms
Maximum cable capacitance	400nF
Minimum loop voltage	17V DC

4.4 MAXIMUM LOOP CABLE LENGTH RECOMMENDATIONS

With an addressable system, some care must be taken when calculating the appropriate cable gauge for the system. The main limitation is that during an alarm condition (maximum current draw), the voltage at all detectors must be at least 17 Volts with at least 5V of superimposed data signal.

The exact calculation equations are beyond the scope of this manual, because of the distributed load of the sounders on the loop, but the following table gives a rough guide for maximum cable lengths at various current loads for 3 different cable gauges.

MAXIMUM LOOP CURRENT (IN ALARM)	500 mA	400 mA	300 mA	200 mA
1mm CSA cable	500 m	625 m	830 m	1250 m
1.5mm CSA cable	750 m	930 m	1250 m	1870 m
2.5mm CSA cable	1000 m	1250 m	1660 m	2500 m

E.g. A system with a maximum load of 300mA using 1.5mm cable can have a maximum loop run of 1250 m end to end. When installed the cable characteristics should meet the following parameters:-

- +ve in to +ve out less than 22 ohms.
- ve in to -ve out less than 22 ohms (may need to temporarily disable isolators to measure).
- +ve to -ve greater than 500k ohm.
- +ve to Earth greater than 1M ohm.
- ve to Earth greater than 1M ohm.
- +ve to -ve less than 50 mV pickup (on AC & DC scales).
- +ve to -ve Capacitance Less than 0.5uF.
- +ve to Earth Capacitance Less than 0.5uF.
- ve to Earth Capacitance Less than 0.5uF
- Maximum loop load 500mA

4.5 BATTERY CALCULATIONS

All systems will have a required stand by time and alarm time. The usual Standby times are 24 hours, 48 hours, or 72 hours, depending on the type of system. Generally 30 minutes of alarm time is considered sufficient.

Information on calculating the required battery size can be found later in this manual. Alternatively, a battery calculation spreadsheet is available. Please contact your distributor for details.

4.6 CHOOSING AUDIBLE & VISUAL WARNING DEVICES

There are a number of options for Audible & visual Devices that can be directly or indirectly connected to one of the 4 loops on Premier Quatro:

A maximum of 64 loop powered sounders are permitted on each loop (which can be either stand-alone sounders or sounders in the bases of detectors). A MAXIMUM OF 250 DEVICES CAN BE CONNECTED TO EACH LOOP, WITH ADDRESSES 1 TO 250 WHICH CAN OCCUR IN ANY ORDER. Short circuit isolators should be used to prevent losing the whole loop in the event of a single short circuit fault. They should be fitted to each zone boundary, such that any short circuit will only affect the devices in 1 zone.

4.6.1 ADDRESSABLE STAND-ALONE SOUNDERS

This type of sounder takes one of the 250 addresses available on each loop. The address is selected via DIP switches 1 to 8. It can be activated individually, or in groups related to its zone number, loop number or panel number (as determined by the cause and effect programmed). An example of this type of sounder is the Zeta Maxitone Addressable Sounder

4.6.2 SOUNDER BASE (Sandwich Sounder – Remote LED Mode)

The sandwich sounder is a type of Platform sounder that fits between a MKII detector and a MKII base. It is controlled via the detector's remote LED pin. As it is a platform sounder the control panel can't "see" it. It is monitored via the loop cable, in a similar way to a conventional sounder

4.6.3 SOUNDER BASE (Sandwich Sounder – Addressed Mode)

The sandwich sounder can also be given an address via the Hand Held Address Programmer (*see section 6.4.1*). When Addressed the sandwich sounder will behave in a similar way as a standalone sounder.

4.6.4 ADDRESSABLE SOUNDER CIRCUIT CONTROLLER

The Zeta addressable sounder circuit controllers (ZASC-MI) can be used to connect one conventional sounder circuit to one address on the loop. It needs external power to be supplied from a suitable 24 V power supply.

4.6.5 PCB CONVENTIONAL SOUNDER CIRCUITS

The termination PCB has 2 conventional sounder circuit outputs, with a maximum capacity of 450 mA each. Please note that conventional sounders should be wired as shown in the diagram below:

*The descriptions of sounders in this section also apply to flashers and combined sounder / flashers.

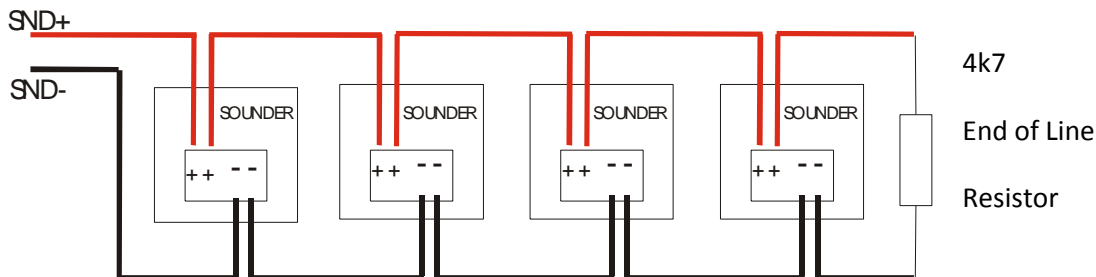

Note: If non-polarized alarm devices (e.g. some types of old mechanical bell, or a relay) are used, then a diode will have to be placed in line with the device to enable fault monitoring. They may also need a back EMF protection diode. (Symptoms: Chattering sounder relays that don't turn off).

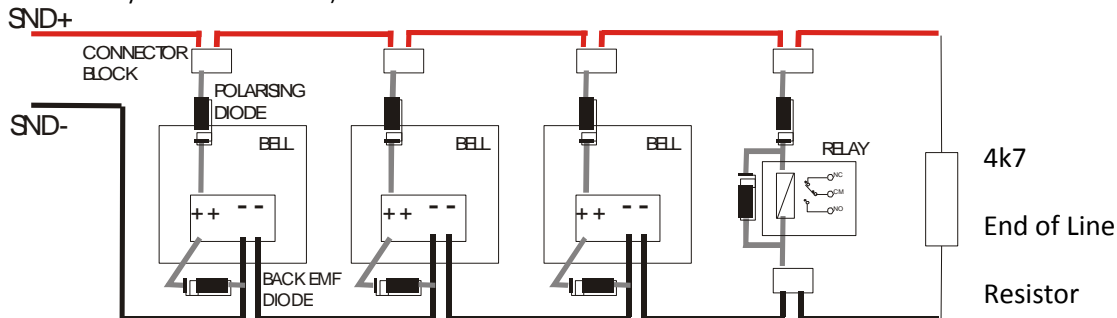

4.6.6 EVACS 16 VOICE ALARM SYSTEM

The Quatro panel can connect to the EVACS 16 system. It sees each channel of the EVACS as a voice sounder, so the panel has control over the individual channels. They will be programmed as part of the usual ACTIONS programming for alert and evacuate tones.

4.6.7 ADVANTAGES AND DISADVANTAGES OF DIFFERENT SOUNDER TYPES

SOUNDER TYPE	ADVANTAGE	DISADVANTAGE
Conventional	Wide range of devices. Devices tend to be cheaper. Immediate start / stop. No quiescent current.	Needs extra cabling. All sounders on each circuit start together
Stand-Alone Addressable or Addressed Sounder Base	No extra cabling. Individually started.	Tends to be more expensive. Maximum 64 per loop. Quiescent current relatively high. Uses device address.
Associated (at detector address)	No extra cabling. Doesn't occupy own address. Individually started.	Not monitored trough protocol. It needs a detector present to operate individually.
Addressable Sounder Circuit Controller	Wide range of devices. Devices tend to be cheaper. Can Add many sounder circuits to system. Sounder circuit can be assigned to zone.	Needs Extra Cabling. Needs External PSU. Quiescent current high. Uses device Address.

4.7 SYSTEM SPARE CAPACITY

The UK Fire alarm system code of Practice for Designing, Installing, Commissioning & maintaining fire alarm systems, BS5839 recommends allowing at least 25% free capacity when designing a fire system.

This is a good precaution as it allows for:-

- Changes to the system requirements before the site is finished
- Additional devices identified as part of the commissioning process
- Future Changes to the building layout (e.g. partitioning an open plan area)

If a system is designed to full capacity, any small additions might mean substantial changes (Extra loops or even having to network an extra panel)

4.8 PRE COMMISSIONING CHECK LIST

The following information is designed to help minimise issues encountered when commissioning a system.

- 1. PANEL.** First fit the panel and connect the mains power supply and batteries. Now with **NO** external circuits or loops connected, turn the panel on and check that the panel runs with no faults.
- 2. LOOPS.** Starting with one loop at a time, check between + & + for continuity and note the resistance (which should be no more than 22Ω maximum (Less than 15Ω recommended)). Carry out the same test between - & -. Note this should be done before any devices are connected. If the isolators have been connected then you will get an open circuit reading. Also make sure that the screen (earth) has continuity and is not showing an open circuit. Now test between the + & - core making sure there is no short circuit, repeat this test between + & screen and - & screen.
- 3. ADDRESS DEVICES.** When you have checked the loop cables, you can now number all the devices and connect loop 1 to the panel. Turn the panel on and autosearch loop 1. Once the panel has finished the autosearch process check that the total devices found match the devices fitted to the loop. If at this stage the panel reports faults (loop open circuit, loop short circuit, earth fault or double addresses), rectify the faults before moving on to the next loop. Repeat this process for each loop (**REMEMBER TO FIT ONE LOOP AT A TIME**).
- 4. CONFIGURE THE PANEL.** Once you have all loops running without any problems, connect the laptop and take a download of the system. Program all the device text, zone text and zone numbers, also any cause and effects requirements. Upload this information in to the panel and test all devices making sure the correct information is shown for each device.

If you have more than one panel, repeat steps one to four.

- 5. NETWORKED SYSTEMS.** If the system is on a network, leave networking the panels until after you have each panel working. Now add one panel at a time and check the network functions between the first two panels. Once you know that the first two panels are communicating ok, then add the third panel and check the network operation between the three panels. Repeat this procedure for each additional panel.

5 MOUNTING THE FIRE ALARM CONTROL PANEL

The Premier Quatro comes with many cable entry holes. If another entry hole is required, it is strongly recommended that the panel door is removed to avoid accidental damage. Also, the back plate which holds the loop cards and power supply should be removed and stored in a safe place. This would also help while fixing the back box to the wall.

5.1 LOCATING THE FIRE ALARM CONTROL PANEL

The control panel should be installed in accordance with the following recommendations:-

The panel should be close to the main entrance of the building, so that it can be viewed by any fire-fighting personnel entering the building.

It should be fitted to a sturdy wall that will not flex unnecessarily.

It should ideally be mounted at eye level, in order for it to be viewed without need of a ladder.

It should be installed in a dry, weatherproof place, preferably NOT in direct sunlight.

It should be easily accessible, so that the responsible person can perform their regular fire alarm checks.

5.2 FIXING THE BACK BOX TO THE WALL

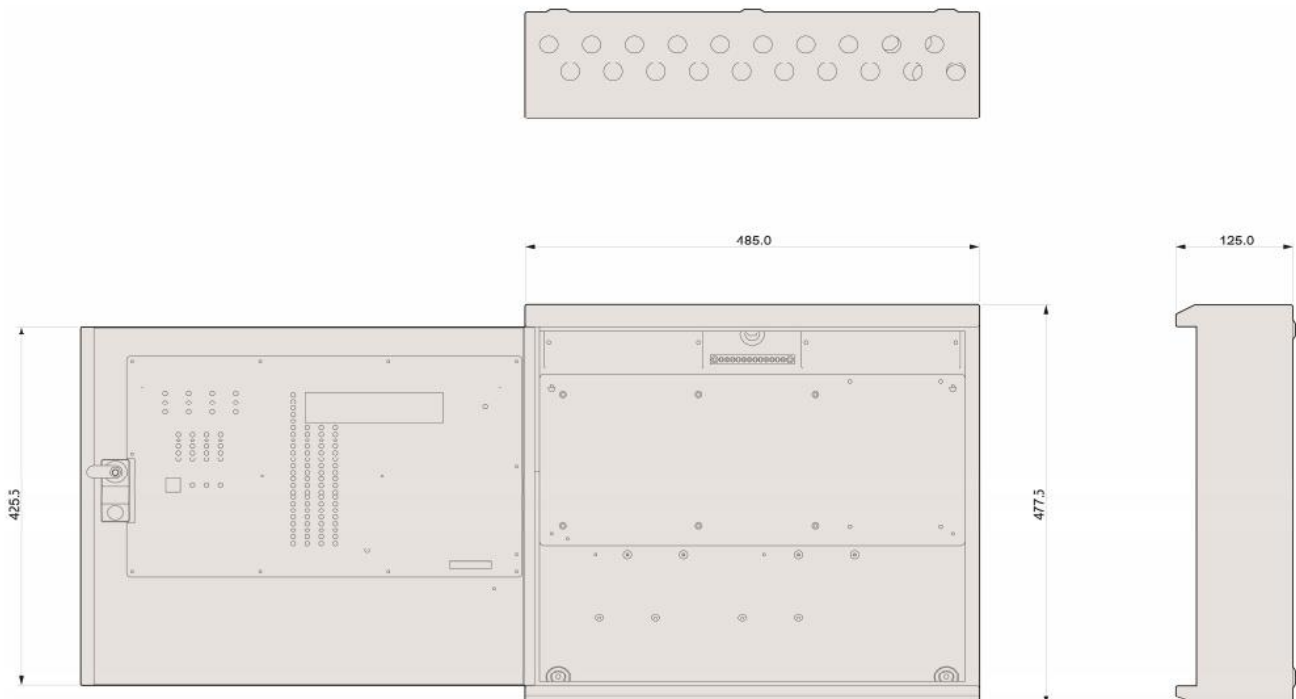

Figure 2: Plan view inside the enclosure without PCBs. Side view for surface installation. (Dimensions: mm)

Fix the enclosure to the wall using the three mounting holes provided (2 circular holes near the bottom of the rear face and one 'keyhole' near the top of the rear face).

Check the build and condition of the wall to decide a suitable screw fixing. The mounting holes are designed for No 8 roundhead or countersunk woodscrews (or similar). Remove any debris from the enclosure. Take care not to damage the FACP during installation.

5.3 MAINS WIRING RECOMMENDATIONS

The Mains supply to the FACP is fixed wiring, using **Fire resisting** 3-core cable (Between 1 mm² and 2.5mm²), fed from an isolating double pole switch fused spur, and fused at 3A. **IT SHOULD NOT BE CONNECTED THROUGH AN RCD.** This should be secure from unauthorised operation and be marked 'FIRE ALARM: DO NOT SWITCH OFF'. The supply must be exclusive to the Fire Panel. **MAKE SURE ANY SPARE ENTRY HOLES ARE COVERED WITH THE GROMMETS PROVIDED.**

For information on how to connect Mains to the Panel's Power Supply PCB, see Section 6.

Also refer to rating information on the mains cover inside the FACP.

5.4 PLANNING CABLE ENTRY

Fig.2 below shows the location of the cable entries to facilitate planning of wiring to be brought to the panel.

The Knock-out cable entries can be easily removed by Tapping with a suitable screwdriver or chisel from outside the control panel box (Take care not to dent or deform the metal enclosure).

If a grommet is removed, fill the hole with a brass cable gland. If any knockout is removed, but subsequently not used, it should be covered up.

The 230V AC Mains cable must be fed into the enclosure via one of the cable entries at the top right corner of the back box. (Refer to "Connecting the Mains Power" in Section 5.1).

5.5 CONNECTING THE MAINS POWER

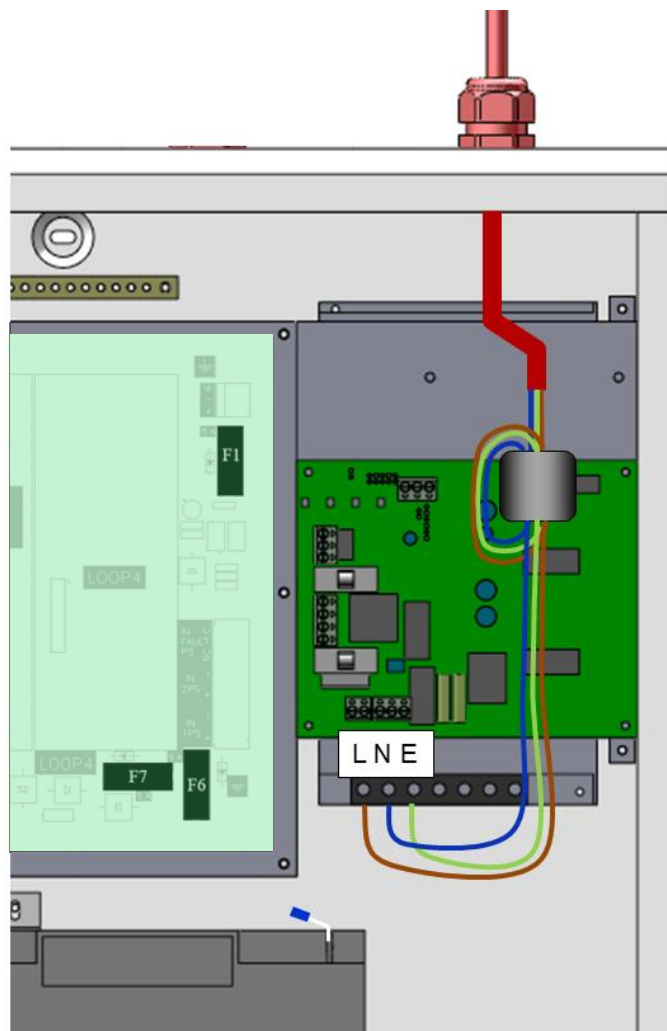

Figure 3: Power Supply PCB layout and Mains connection details

The panel should be connected to mains supply by a 3A rated spur to the fuse box with 1mm² to 2.5mm² 3-core cables. Nothing else should be connected to this supply. The cable should be fire resistant. NB It is recommended that the mains cable should pass twice through the ferrite supplied with the panel, to improve the panel's immunity to electromagnetic interference. The ferrite should be positioned between the mains entry port and the power supply cage.

The AC Live (L), Earth (E) and Neutral (N) connections are marked on the power supply cage (top right of Figure 3). It is essential that the mains Earth cable is connected to the PSU's Earth terminal. The incoming mains cable should be kept separate from the loop cables to help minimize mains interference.

Once the mains are connected, the panel door should be closed BEFORE turning on the mains power. This will protect the installer from the chance of receiving an electric shock.

MAKE SURE ANY SPARE ENTRY HOLES ARE COVERED WITH PLASTIC GROMMETS.

It is advisable to apply power to the panel before connecting any devices, to check for correct operation, and to familiarise yourself with the fire alarm panels controls.

5.6 CONNECTING THE BATTERIES

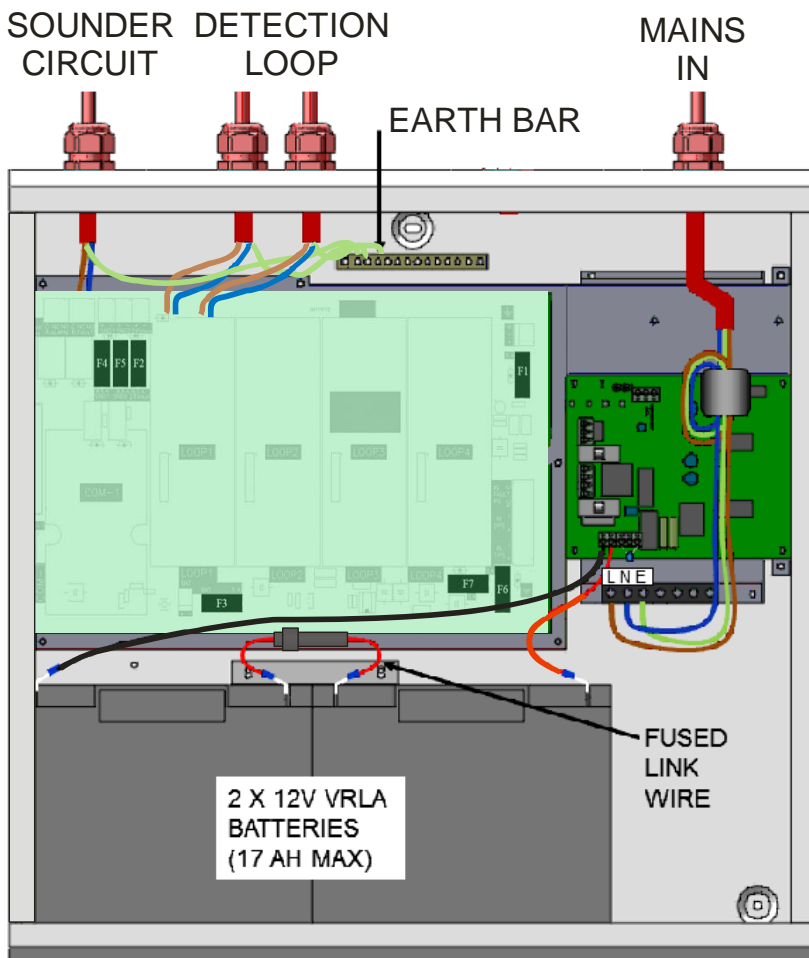

Figure 4: Battery location and connection details.

To calculate the exact requirement, use the equation in section 17. STANDBY BATTERY REQUIREMENTS.

The two batteries are wired in series.

The **+ve** of one battery is connected to the **red** battery lead.

The **-ve** of the other battery is connected to the **black** battery lead.

The **-ve** of the first battery is connected to the **+ve** of the second battery using the link wire supplied.

The battery leads will be factory-fitted to either the 5A PSE or to the motherboard (depending upon which version of the panel has been supplied).

Recommended Battery Types:

Small / Lightly loaded systems – Powersonic 12V, 7 Ah; Heavily loaded systems, or systems requiring longer stand by – Powersonic 12V 17 Ah. Other makes and sizes of battery may be suitable. Calculate the standby requirements to determine the most suitable size of battery

6 - INSTALLING THE DEVICES

6.1 ADDRESSABLE LOOP WIRING

The Premier Quatro can be fitted with 1 or 4 addressable loop cards. One addressable loop can be connected to each loop card. Addressable detectors, addressable call points, addressable loop powered sounders and several other interface units can be fitted to these loops. A MAXIMUM OF 250 ADDRESSES CAN BE CONNECTED TO EACH LOOP. We recommend that the first and last devices on a loop have isolator bases fitted. Also the last device on each zone should have an isolator fitted. This is to prevent a short circuit fault in one zone affecting another zone. The screen cable at each end of the loop (not shown below) must be connected to the Panel's earth bar.

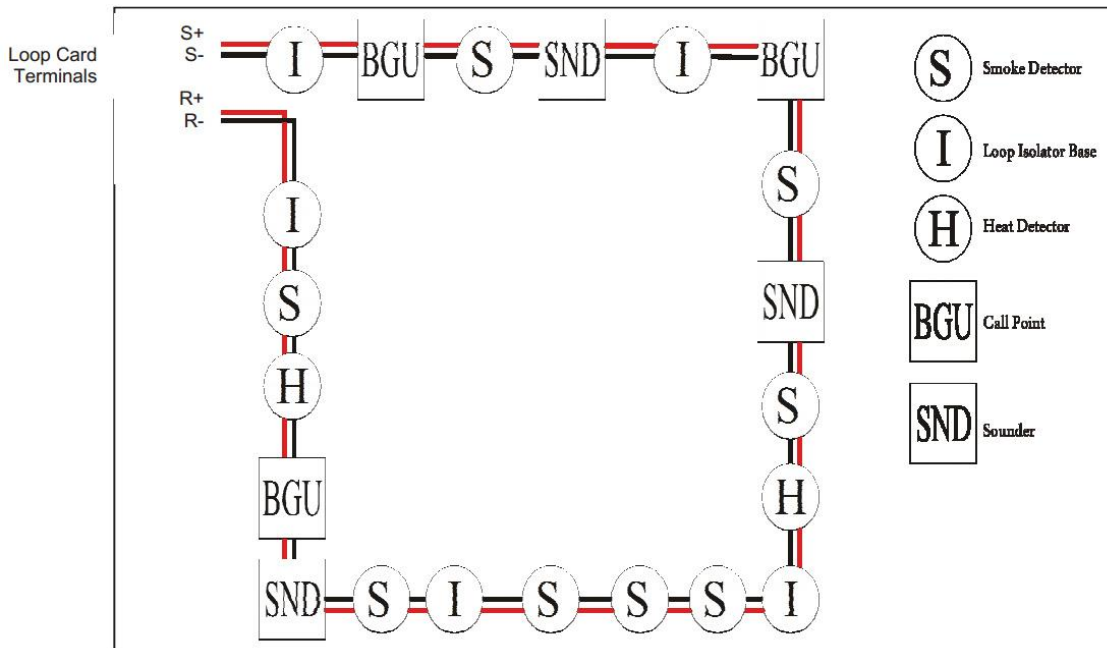

Figure 5: Example of addressable loop wiring (top) & connections to loop cards (bottom)

6.2 ADDRESSABLE LOOPS (Pre commissioning check)

At this stage it is important to remember devices (e.g. detectors, call points, sounders etc.) should not be connected yet, if a high voltage "Megger" type tester is to be used to check for continuity of the loop wiring.

Pre-Commissioning Cable Checks

- +ve in to +ve out less than 22 ohms.
 - ve in to -ve out less than 22 ohms (may need to temporarily disable isolators to measure).
 - +ve to -ve greater than 500k ohm.
 - +ve to Earth greater than 1M ohm.
 - ve to Earth greater than 1M ohm.
 - +ve to -ve less than 50 mV pickup (on AC & DC scales).
 - +ve to -ve Capacitance Less than 0.5uF.
 - +ve to Earth Capacitance Less than 0.5uF.
 - ve to Earth Capacitance Less than 0.5uF
- Maximum loop load 500mA

6.3 SPECIFIC DEVICE WIRING INSTRUCTIONS

6.3.1 CP3/AD Manual Call Point

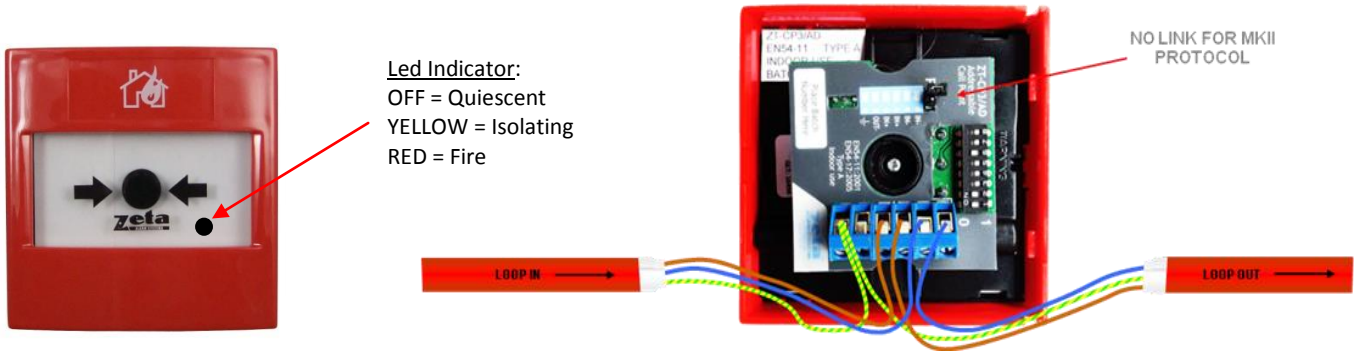

The CP3/AD call point has a built in isolator which can be wired in circuit or not used. This is done by means of not wiring to the negative out terminal on the call point. The following terminals are used for connecting the call point.

- 2 x Negative in terminals (note if you only connect to the negative in terminals then the isolator is bypassed)
- 1 x Positive in terminal
- 1 x Positive out terminal
- 1 x Negative out terminal (note if used puts the isolator in circuit)
- 1 x Earth terminal used to connect the cable screen

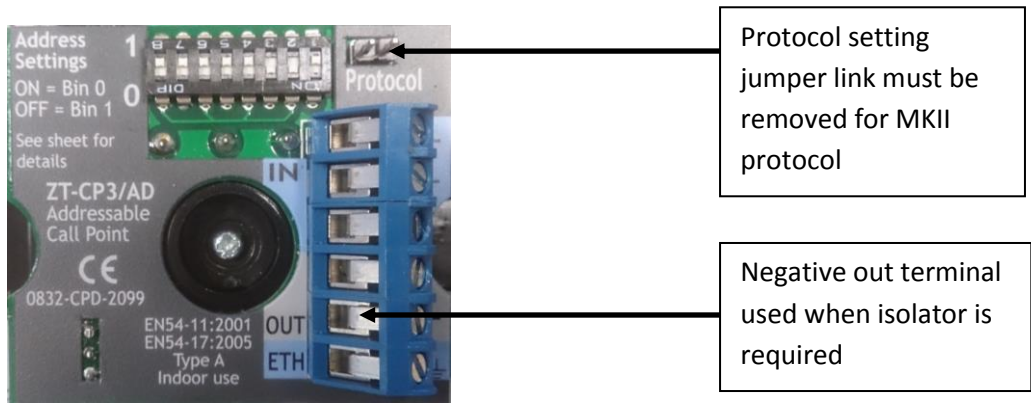

6.3.2 MKII detectors (All types)

Base connection

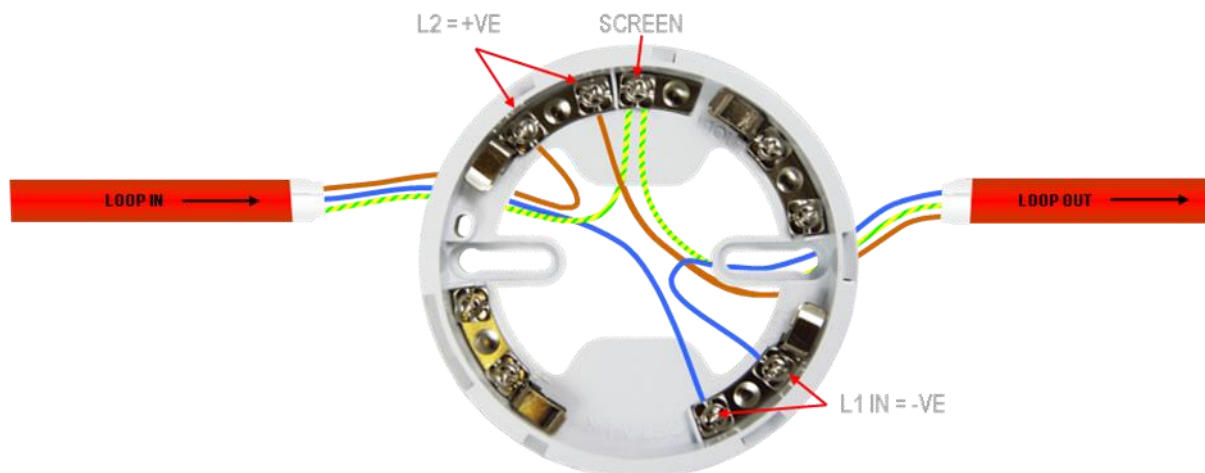

The connection for the detectors bases is made as follows:
 Terminal L1IN is -ve (Blue)
 Terminal L2 is +ve (Brown)
 These are the only two connections required.



Deep Base MKII-CB/D



Common Base MKII-CB

6.3.3 ZAI - MI Input Module

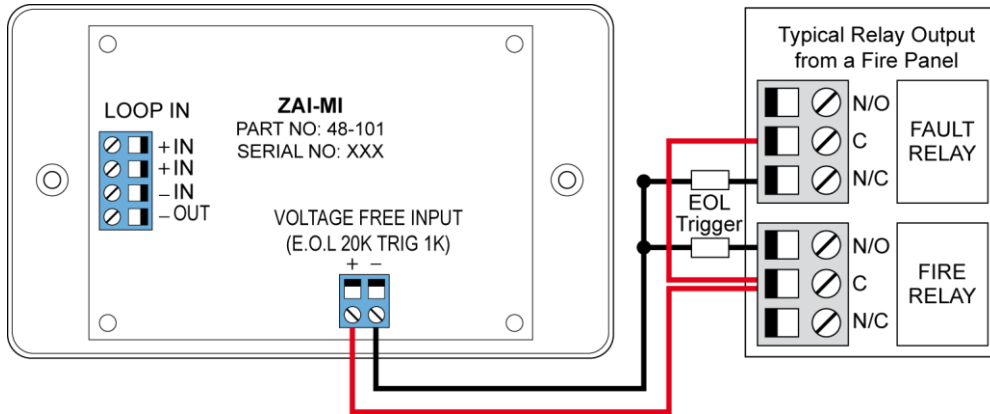

The end of line resistor value is 20KΩ and the trigger resistor value is 1kΩ.

6.3.4 ZAIO - MI Input/output Module

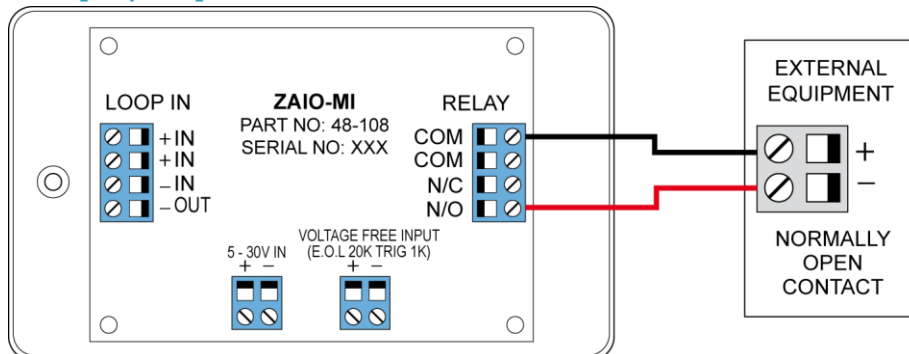

The end of line resistor value is 20KΩ and the trigger resistor value is 1KΩ.

6.3.5 ZASC – MI Sounder Control Module

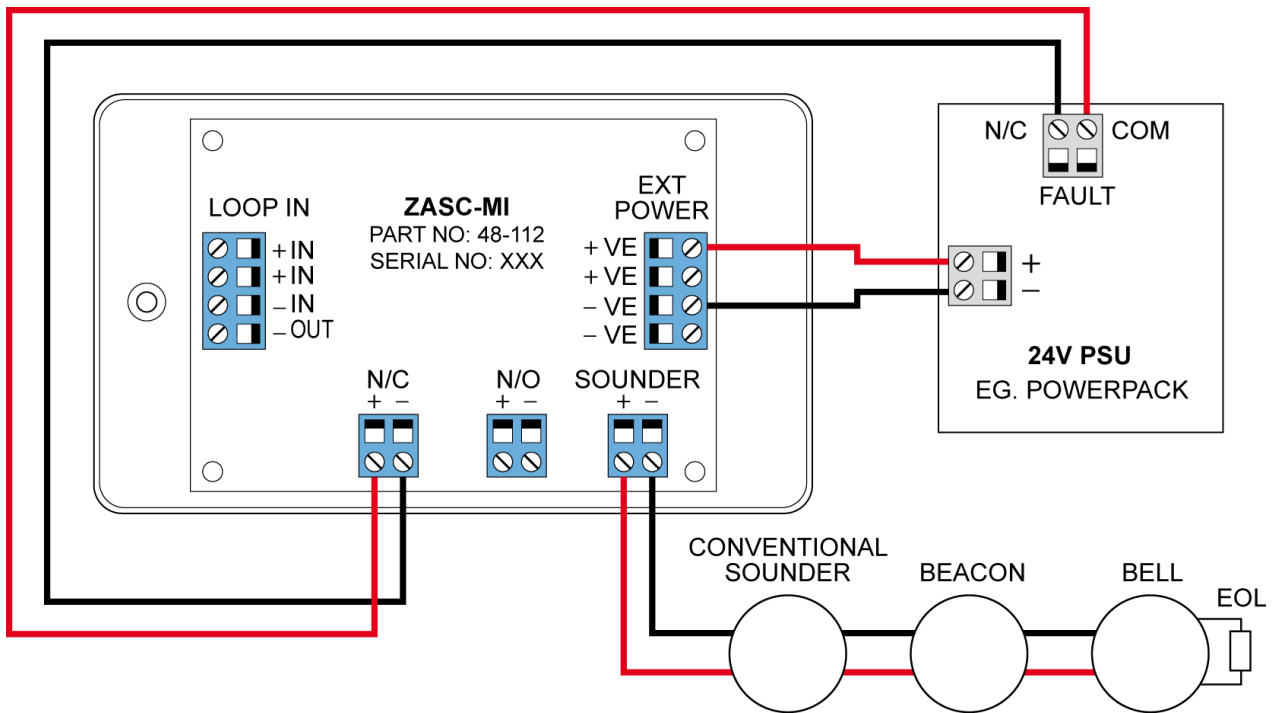

The ZASC requires an external 24vdc power supply (as shown in the above diagram). The EOL for the sounder circuit is 10KΩ. When using the ZASC make sure the PSU being used has a fault output relay, so that in the event of a power supply fault it is reported to the control panel.

Note: All Power Supplies used on fire alarm systems MUST comply with EN54 part 4

6.3.6 ZAZM – MI Conventional Zone Module

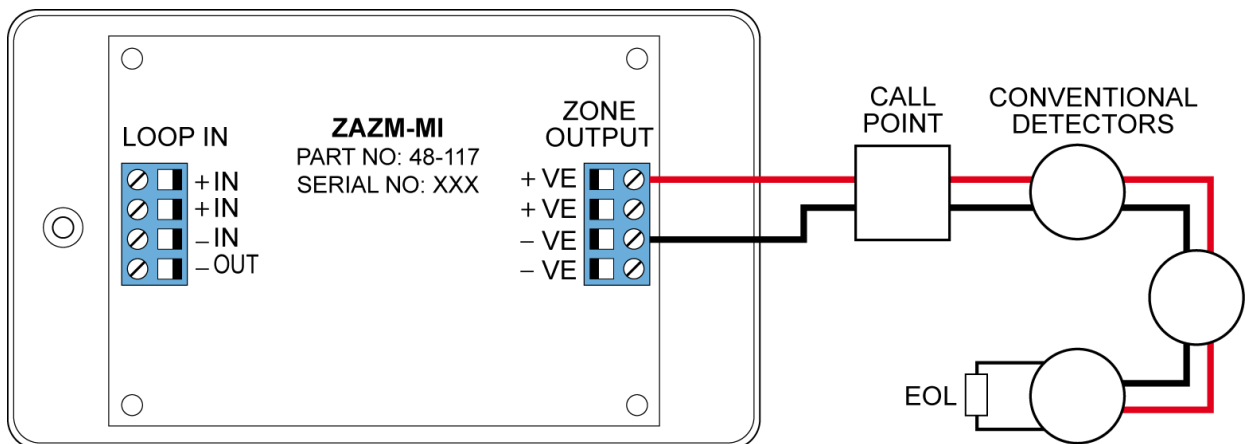

The ZAZM powers the conventional zone from the addressable systems loop, so no external power supply is required. The EOL for the zone is 6.2KΩ

6.3.7 Xtratone Sounder/Sounder Flasher



The Xtratone sounder or sounder flasher is a wall mount sounder. The programming of the sounder is done via the DIP switch mounted on the inside (front). It may also be programmed via the handheld programming tool.

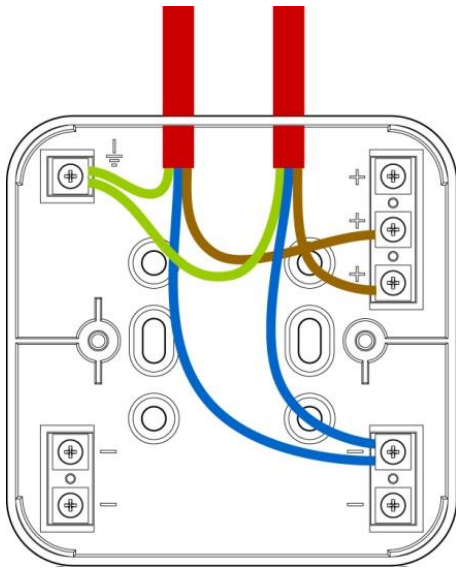

Connecting the sounder is done using the terminals in the back box of the device. Please refer to the above diagram.

6.3.8 Sandwich Sounder

The sandwich sounder has no wiring to connect as it just clips straight on to a standard base. It will run as a platform sounder using no address, and is controlled by the detector fitted to it. It can also be given an address via the handheld programming tool making it an addressable sounder. (**Note:** If the sandwich sounder has NO ADDRESS it will ONLY function with an addressed detector fitted on top of it.)



6.3.9 Remote LED Indicator



Ceiling Mount (MKII-ARL/C)



Wall Mount (MKII-ARL/W)

There are two versions of the remote LED, Wall mounted and Ceiling mounted. The ceiling mounted version requires a standard detector base.

Each version of the remote LED can monitor 1 or up to 12 devices. The way in which the LED is programmed is either via the DIP switches on the device or soft addressing via the handheld programmer.

Connection to an Addressable Detector:

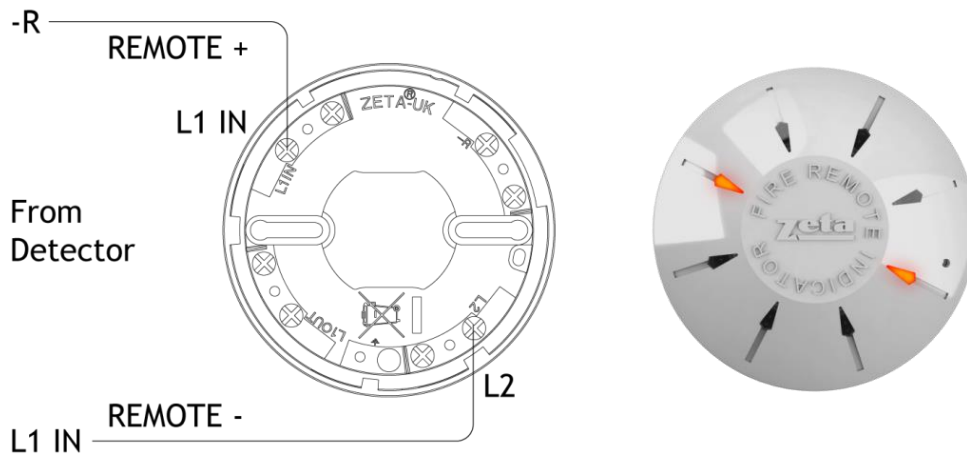

Fig 1
Fig 1 shows the connections for a ceiling mount version remote LED

Connection to an Addressable Detector:

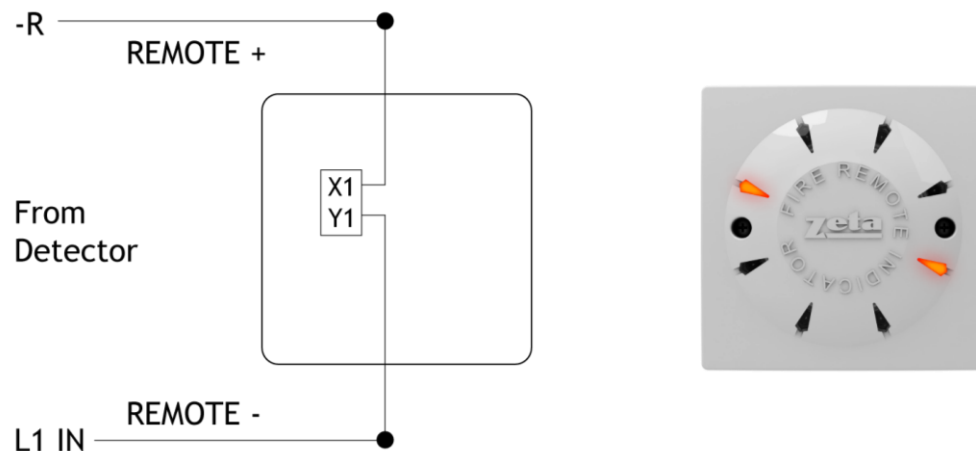

Fig 2
Fig 1 shows the connections for a wall mount version remote LED

6.4 SETTING THE DEVICE ADDRESS (DETECTORS, CALL POINTS, SOUNDERS & INTERFACE UNITS)

6.4.1 SOFT AND HARD PROGRAMMING



The MKII Handheld Programmer is designed to complement all MKII devices and to assist the commissioning engineer on site. The unit will softly address all devices without using the incorporated dip-switch on the field devices. Smoke and heat detectors can be tested when plugged on the programmer and alarm LED's can be verified prior to installation. The MKII Programmer can also re-program the OPT-HEAT detectors to either heat or smoke detector.

If the address programming tool is not available, the device Address can still be set with a DIP switch on the rear of the device.

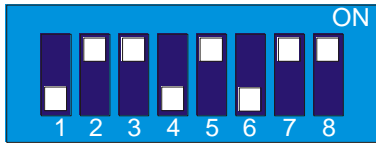

The Address setting is binary, with the ON position being binary 0, and the OFF position being binary 1.

If you are not familiar with binary, check the table on page 14, or use the following rule:

- Switch 8 off = Add 128
- Switch 7 off = Add 64
- Switch 6 off = Add 32
- Switch 5 off = Add 16
- Switch 4 off = Add 8
- Switch 3 off = Add 4
- Switch 2 off = Add 2
- Switch 1 off = Add 1

The example shown would be: switches 6, 4 & 1 = 32 + 8 + 1 = Address 41

6.4.2 DIP SWITCH ADDRESS SETTINGS - FULL TABLE

ADDRESS	SWITCHES								ADDRESS	SWITCHES								ADDRESS	SWITCHES										
	1	2	3	4	5	6	7	8		1	2	3	4	5	6	7	8		1	2	3	4	5	6	7	8			
0	=	N	O	T		U	S	E	D	43	=	OFF	OFF	ON	OFF	ON	OFF	ON	ON	86	=	ON	OFF	OFF	ON	OFF	ON	OFF	ON
1	=	OFF	ON	ON	ON	ON	ON	ON	ON	44	=	ON	ON	OFF	OFF	ON	OFF	ON	ON	87	=	OFF	OFF	OFF	ON	OFF	ON	OFF	ON
2	=	ON	OFF	ON	ON	ON	ON	ON	ON	45	=	OFF	ON	OFF	OFF	ON	OFF	ON	ON	88	=	ON	ON	ON	OFF	OFF	ON	OFF	ON
3	=	OFF	OFF	ON	ON	ON	ON	ON	ON	46	=	ON	OFF	OFF	OFF	ON	OFF	ON	ON	89	=	OFF	ON	ON	OFF	OFF	ON	OFF	ON
4	=	ON	ON	OFF	ON	ON	ON	ON	ON	47	=	OFF	OFF	OFF	OFF	ON	OFF	ON	ON	90	=	ON	OFF	ON	OFF	OFF	ON	OFF	ON
5	=	OFF	ON	OFF	ON	ON	ON	ON	ON	48	=	ON	ON	ON	ON	OFF	OFF	ON	ON	91	=	OFF	OFF	ON	OFF	OFF	ON	OFF	ON
6	=	ON	OFF	OFF	ON	ON	ON	ON	ON	49	=	OFF	ON	ON	ON	OFF	OFF	ON	ON	92	=	ON	ON	OFF	OFF	OFF	ON	OFF	ON
7	=	OFF	OFF	OFF	ON	ON	ON	ON	ON	50	=	ON	OFF	ON	ON	OFF	OFF	ON	ON	93	=	OFF	ON	OFF	OFF	OFF	ON	OFF	ON
8	=	ON	ON	ON	OFF	ON	ON	ON	ON	51	=	OFF	OFF	ON	ON	OFF	OFF	ON	ON	94	=	ON	OFF	OFF	OFF	OFF	ON	OFF	ON
9	=	OFF	ON	ON	OFF	ON	ON	ON	ON	52	=	ON	ON	OFF	ON	OFF	OFF	ON	ON	95	=	OFF	OFF	OFF	OFF	OFF	ON	OFF	ON
10	=	ON	OFF	ON	OFF	ON	ON	ON	ON	53	=	OFF	ON	OFF	ON	OFF	OFF	ON	ON	96	=	ON	ON	ON	ON	ON	OFF	OFF	ON
11	=	OFF	OFF	ON	OFF	ON	ON	ON	ON	54	=	ON	OFF	OFF	ON	OFF	OFF	ON	ON	97	=	OFF	ON	ON	ON	ON	OFF	OFF	ON
12	=	ON	ON	OFF	OFF	ON	ON	ON	ON	55	=	OFF	OFF	OFF	ON	OFF	OFF	ON	ON	98	=	ON	OFF	ON	ON	ON	OFF	OFF	ON
13	=	OFF	ON	OFF	OFF	ON	ON	ON	ON	56	=	ON	ON	ON	OFF	OFF	OFF	ON	ON	99	=	OFF	OFF	ON	ON	ON	OFF	OFF	ON
14	=	ON	OFF	OFF	OFF	ON	ON	ON	ON	57	=	OFF	ON	ON	OFF	OFF	OFF	ON	ON	100	=	ON	ON	OFF	ON	ON	OFF	OFF	ON

15	=	OFF	OFF	OFF	OFF	ON	ON	ON	ON	58	=	ON	OFF	ON	OFF	OFF	OFF	ON	ON	101	=	OFF	ON	OFF	ON	ON	OFF	OFF	ON
16	=	ON	ON	ON	ON	OFF	ON	ON	ON	59	=	OFF	OFF	ON	OFF	OFF	OFF	ON	ON	102	=	ON	OFF	OFF	ON	ON	OFF	OFF	ON
17	=	OFF	ON	ON	ON	OFF	ON	ON	ON	60	=	ON	ON	OFF	OFF	OFF	OFF	ON	ON	103	=	OFF	OFF	OFF	ON	ON	OFF	OFF	ON
18	=	ON	OFF	ON	ON	OFF	ON	ON	ON	61	=	OFF	ON	OFF	OFF	OFF	OFF	ON	ON	104	=	ON	ON	ON	OFF	ON	OFF	OFF	ON
19	=	OFF	OFF	ON	ON	OFF	ON	ON	ON	62	=	ON	OFF	OFF	OFF	OFF	OFF	ON	ON	105	=	OFF	ON	ON	OFF	ON	OFF	OFF	ON
20	=	ON	ON	OFF	ON	OFF	ON	ON	ON	63	=	OFF	OFF	OFF	OFF	OFF	OFF	ON	ON	106	=	ON	OFF	ON	OFF	ON	OFF	OFF	ON
21	=	OFF	ON	OFF	ON	OFF	ON	ON	ON	64	=	ON	ON	ON	ON	ON	ON	OFF	ON	107	=	OFF	OFF	ON	OFF	ON	OFF	OFF	ON
22	=	ON	OFF	OFF	ON	OFF	ON	ON	ON	65	=	OFF	ON	ON	ON	ON	ON	OFF	ON	108	=	ON	ON	OFF	OFF	ON	OFF	OFF	ON
23	=	OFF	OFF	OFF	ON	OFF	ON	ON	ON	66	=	ON	OFF	ON	ON	ON	ON	OFF	ON	109	=	OFF	ON	OFF	OFF	ON	OFF	OFF	ON
24	=	ON	ON	ON	OFF	OFF	ON	ON	ON	67	=	OFF	OFF	ON	ON	ON	ON	OFF	ON	110	=	ON	OFF	OFF	OFF	ON	OFF	OFF	ON
25	=	OFF	ON	ON	OFF	OFF	ON	ON	ON	68	=	ON	ON	OFF	ON	ON	ON	OFF	ON	111	=	OFF	OFF	OFF	OFF	ON	OFF	OFF	ON
26	=	ON	OFF	ON	OFF	OFF	ON	ON	ON	69	=	OFF	ON	OFF	ON	ON	ON	OFF	ON	112	=	ON	ON	ON	ON	OFF	OFF	OFF	ON
27	=	OFF	OFF	ON	OFF	OFF	ON	ON	ON	70	=	ON	OFF	OFF	ON	ON	ON	OFF	ON	113	=	OFF	ON	ON	ON	OFF	OFF	OFF	ON
28	=	ON	ON	OFF	OFF	OFF	ON	ON	ON	71	=	OFF	OFF	OFF	ON	ON	ON	OFF	ON	114	=	ON	OFF	ON	ON	OFF	OFF	OFF	ON
29	=	OFF	ON	OFF	OFF	OFF	ON	ON	ON	72	=	ON	ON	ON	OFF	ON	ON	OFF	ON	115	=	OFF	OFF	ON	ON	OFF	OFF	OFF	ON
30	=	ON	OFF	OFF	OFF	OFF	ON	ON	ON	73	=	OFF	ON	ON	OFF	ON	ON	OFF	ON	116	=	ON	ON	OFF	ON	OFF	OFF	OFF	ON
31	=	OFF	OFF	OFF	OFF	OFF	ON	ON	ON	74	=	ON	OFF	ON	OFF	ON	ON	OFF	ON	117	=	OFF	ON	OFF	ON	OFF	OFF	OFF	ON
32	=	ON	ON	ON	ON	ON	OFF	ON	ON	75	=	OFF	OFF	ON	OFF	ON	ON	OFF	ON	118	=	ON	OFF	OFF	ON	OFF	OFF	OFF	ON
33	=	OFF	ON	ON	ON	ON	OFF	ON	ON	76	=	ON	ON	OFF	OFF	ON	ON	OFF	ON	119	=	OFF	OFF	OFF	ON	OFF	OFF	OFF	ON
34	=	ON	OFF	ON	ON	ON	OFF	ON	ON	77	=	OFF	ON	OFF	OFF	ON	ON	OFF	ON	120	=	ON	ON	ON	OFF	OFF	OFF	OFF	ON
35	=	OFF	OFF	ON	ON	ON	OFF	ON	ON	78	=	ON	OFF	OFF	OFF	ON	ON	OFF	ON	121	=	OFF	ON	ON	OFF	OFF	OFF	OFF	ON
36	=	ON	ON	OFF	ON	ON	OFF	ON	ON	79	=	OFF	OFF	OFF	OFF	ON	ON	OFF	ON	122	=	ON	OFF	ON	OFF	OFF	OFF	OFF	ON
37	=	OFF	ON	OFF	ON	ON	OFF	ON	ON	80	=	ON	ON	ON	ON	OFF	ON	OFF	ON	123	=	OFF	OFF	ON	OFF	OFF	OFF	OFF	ON
38	=	ON	OFF	OFF	ON	ON	OFF	ON	ON	81	=	OFF	ON	ON	ON	OFF	ON	OFF	ON	124	=	ON	ON	OFF	OFF	OFF	OFF	OFF	ON
39	=	OFF	OFF	OFF	ON	ON	OFF	ON	ON	82	=	ON	OFF	ON	ON	OFF	ON	OFF	ON	125	=	OFF	ON	OFF	OFF	OFF	OFF	OFF	ON
40	=	ON	ON	ON	OFF	ON	OFF	ON	ON	83	=	OFF	OFF	ON	ON	OFF	ON	OFF	ON	126	=	ON	OFF	OFF	OFF	OFF	OFF	OFF	ON
41	=	OFF	ON	ON	OFF	ON	OFF	ON	ON	84	=	ON	ON	OFF	ON	OFF	ON	OFF	ON	127	=	OFF	OFF	OFF	OFF	OFF	OFF	OFF	ON
42	=	ON	OFF	ON	OFF	ON	OFF	ON	ON	85	=	OFF	ON	OFF	ON	OFF	ON	OFF	ON										

ADDRESS	SWITCHES								ADDRESS	SWITCHES								ADDRESS	SWITCHES										
	1	2	3	4	5	6	7	8		1	2	3	4	5	6	7	8		1	2	3	4	5	6	7	8			
128	=	ON	ON	ON	ON	ON	ON	ON	OFF	171	=	OFF	OFF	ON	OFF	ON	OFF	ON	OFF	214	=	ON	OFF	OFF	ON	OFF	ON	OFF	OFF
129	=	OFF	ON	ON	ON	ON	ON	ON	OFF	172	=	ON	ON	OFF	OFF	ON	OFF	ON	OFF	215	=	OFF	OFF	OFF	ON	OFF	ON	OFF	OFF
123	=	ON	OFF	ON	ON	ON	ON	ON	OFF	173	=	OFF	ON	OFF	OFF	ON	OFF	ON	OFF	216	=	ON	ON	ON	OFF	OFF	ON	OFF	OFF
131	=	OFF	OFF	ON	ON	ON	ON	ON	OFF	174	=	ON	OFF	OFF	OFF	ON	OFF	ON	OFF	217	=	OFF	ON	ON	OFF	OFF	ON	OFF	OFF
132	=	ON	ON	OFF	ON	ON	ON	ON	OFF	175	=	OFF	OFF	OFF	OFF	ON	OFF	ON	OFF	218	=	ON	OFF	ON	OFF	OFF	ON	OFF	OFF
133	=	OFF	ON	OFF	ON	ON	ON	ON	OFF	176	=	ON	ON	ON	ON	OFF	OFF	ON	OFF	219	=	OFF	OFF	ON	OFF	OFF	ON	OFF	OFF
134	=	ON	OFF	OFF	ON	ON	ON	ON	OFF	177	=	OFF	ON	ON	ON	OFF	OFF	ON	OFF	220	=	ON	ON	OFF	OFF	OFF	ON	OFF	OFF
135	=	OFF	OFF	OFF	ON	ON	ON	ON	OFF	178	=	ON	OFF	ON	ON	OFF	OFF	ON	OFF	221	=	OFF	ON	OFF	OFF	OFF	ON	OFF	OFF
136	=	ON	ON	ON	OFF	ON	ON	ON	OFF	179	=	OFF	OFF	ON	ON	OFF	OFF	ON	OFF	222	=	ON	OFF	OFF	OFF	OFF	ON	OFF	OFF
137	=	OFF	ON	ON	OFF	ON	ON	ON	OFF	180	=	ON	ON	OFF	ON	OFF	OFF	ON	OFF	223	=	OFF	OFF	OFF	OFF	OFF	ON	OFF	OFF
138	=	ON	OFF	ON	OFF	ON	ON	ON	OFF	181	=	OFF	ON	OFF	ON	OFF	OFF	ON	OFF	224	=	ON	ON	ON	ON	ON	OFF	OFF	OFF
139	=	OFF	OFF	ON	OFF	ON	ON	ON	OFF	182	=	ON	OFF	OFF	ON	OFF	OFF	ON	OFF	225	=	OFF	ON	ON	ON	ON	OFF	OFF	OFF
140	=	ON	ON	OFF	OFF	ON	ON	ON	OFF	183	=	OFF	OFF	OFF	ON	OFF	OFF	ON	OFF	226	=	ON	OFF	ON	ON	ON	OFF	OFF	OFF
141	=	OFF	ON	OFF	OFF	ON	ON	ON	OFF	184	=	ON	ON	ON	OFF	OFF	OFF	ON	OFF	227	=	OFF	OFF	ON	ON	ON	OFF	OFF	OFF
142	=	ON	OFF	OFF	OFF	ON	ON	ON	OFF	185	=	OFF	ON	ON	OFF	OFF	OFF	ON	OFF	228	=	ON	ON	OFF	ON	ON	OFF	OFF	OFF
143	=	OFF	OFF	OFF	OFF	ON	ON	ON	OFF	186	=	ON	OFF	ON	OFF	OFF	OFF	ON	OFF	229	=	OFF	ON	OFF	ON	ON	OFF	OFF	OFF
144	=	ON	ON	ON	ON	OFF	ON	ON	OFF	187	=	OFF	OFF	ON	OFF	OFF	OFF	ON	OFF	230	=	ON	OFF	OFF	ON	ON	OFF	OFF	OFF

145	=	OFF	ON	ON	ON	OFF	ON	ON	OFF	188	=	ON	ON	OFF	OFF	OFF	ON	OFF	231	=	OFF	OFF	OFF	ON	ON	OFF	OFF	OFF
146	=	ON	OFF	ON	ON	OFF	ON	ON	OFF	189	=	OFF	ON	OFF	OFF	OFF	ON	OFF	232	=	ON	ON	ON	OFF	ON	OFF	OFF	OFF
147	=	OFF	OFF	ON	ON	OFF	ON	ON	OFF	190	=	ON	OFF	OFF	OFF	OFF	ON	OFF	233	=	OFF	ON	ON	OFF	ON	OFF	OFF	OFF
148	=	ON	ON	OFF	ON	OFF	ON	ON	OFF	191	=	OFF	OFF	OFF	OFF	OFF	ON	OFF	234	=	ON	OFF	ON	OFF	ON	OFF	OFF	OFF
149	=	OFF	ON	OFF	ON	OFF	ON	ON	OFF	192	=	ON	ON	ON	ON	ON	OFF	OFF	235	=	OFF	OFF	ON	OFF	ON	OFF	OFF	OFF
150	=	ON	OFF	OFF	ON	OFF	ON	ON	OFF	193	=	OFF	ON	ON	ON	ON	OFF	OFF	236	=	ON	ON	OFF	OFF	ON	OFF	OFF	OFF
151	=	OFF	OFF	OFF	ON	OFF	ON	ON	OFF	194	=	ON	OFF	ON	ON	ON	OFF	OFF	237	=	OFF	ON	OFF	OFF	ON	OFF	OFF	OFF
152	=	ON	ON	ON	OFF	OFF	ON	ON	OFF	195	=	OFF	OFF	ON	ON	ON	OFF	OFF	238	=	ON	OFF	OFF	OFF	ON	OFF	OFF	OFF
153	=	OFF	ON	ON	OFF	OFF	ON	ON	OFF	196	=	ON	ON	OFF	ON	ON	OFF	OFF	239	=	OFF	OFF	OFF	OFF	ON	OFF	OFF	OFF
154	=	ON	OFF	ON	OFF	OFF	ON	ON	OFF	197	=	OFF	ON	OFF	ON	ON	OFF	OFF	240	=	ON	ON	ON	ON	OFF	OFF	OFF	OFF
155	=	OFF	OFF	ON	OFF	OFF	ON	ON	OFF	198	=	ON	OFF	OFF	ON	ON	ON	OFF	241	=	OFF	ON	ON	ON	OFF	OFF	OFF	OFF
156	=	ON	ON	OFF	OFF	OFF	ON	ON	OFF	199	=	OFF	OFF	OFF	ON	ON	ON	OFF	242	=	ON	OFF	ON	ON	OFF	OFF	OFF	OFF
157	=	OFF	ON	OFF	OFF	OFF	ON	ON	OFF	200	=	ON	ON	ON	OFF	ON	ON	OFF	243	=	OFF	OFF	ON	ON	OFF	OFF	OFF	OFF
158	=	ON	OFF	OFF	OFF	OFF	ON	ON	OFF	201	=	OFF	ON	ON	OFF	ON	ON	OFF	244	=	ON	ON	OFF	ON	OFF	OFF	OFF	OFF
159	=	OFF	OFF	OFF	OFF	OFF	ON	ON	OFF	202	=	ON	OFF	ON	OFF	ON	ON	OFF	245	=	OFF	ON	OFF	ON	OFF	OFF	OFF	OFF
160	=	ON	ON	ON	ON	ON	OFF	ON	OFF	203	=	OFF	OFF	ON	OFF	ON	ON	OFF	246	=	ON	OFF	OFF	ON	OFF	OFF	OFF	OFF
161	=	OFF	ON	ON	ON	ON	OFF	ON	OFF	204	=	ON	ON	OFF	OFF	ON	ON	OFF	247	=	OFF	OFF	OFF	ON	OFF	OFF	OFF	OFF
162	=	ON	OFF	ON	ON	ON	OFF	ON	OFF	205	=	OFF	ON	OFF	OFF	ON	ON	OFF	248	=	ON	ON	ON	OFF	OFF	OFF	OFF	OFF
163	=	OFF	OFF	ON	ON	ON	OFF	ON	OFF	206	=	ON	OFF	OFF	OFF	ON	ON	OFF	249	=	OFF	ON	ON	OFF	OFF	OFF	OFF	OFF
164	=	ON	ON	OFF	ON	ON	OFF	ON	OFF	207	=	OFF	OFF	OFF	OFF	ON	ON	OFF	250	=	ON	OFF	ON	OFF	OFF	OFF	OFF	OFF
165	=	OFF	ON	OFF	ON	ON	OFF	ON	OFF	208	=	ON	ON	ON	ON	OFF	ON	OFF	251	=	N	O	T		U	S	E	D
166	=	ON	OFF	OFF	ON	ON	OFF	ON	OFF	209	=	OFF	ON	ON	ON	OFF	ON	OFF	252	=	N	O	T		U	S	E	D
167	=	OFF	OFF	OFF	ON	ON	OFF	ON	OFF	210	=	ON	OFF	ON	ON	OFF	ON	OFF	253	=	N	O	T		U	S	E	D
168	=	ON	ON	ON	OFF	ON	OFF	ON	OFF	211	=	OFF	OFF	ON	ON	OFF	ON	OFF	254	=	N	O	T		U	S	E	D
169	=	OFF	ON	ON	OFF	ON	OFF	ON	OFF	212	=	ON	ON	OFF	ON	OFF	ON	OFF	255	=	N	O	T		U	S	E	D
170	=	ON	OFF	ON	OFF	ON	OFF	ON	OFF	213	=	OFF	ON	OFF	ON	OFF	ON	OFF										

6.5 FIRE RELAY (VOLTAGE FREE CHANGEOVER CONTACTS)

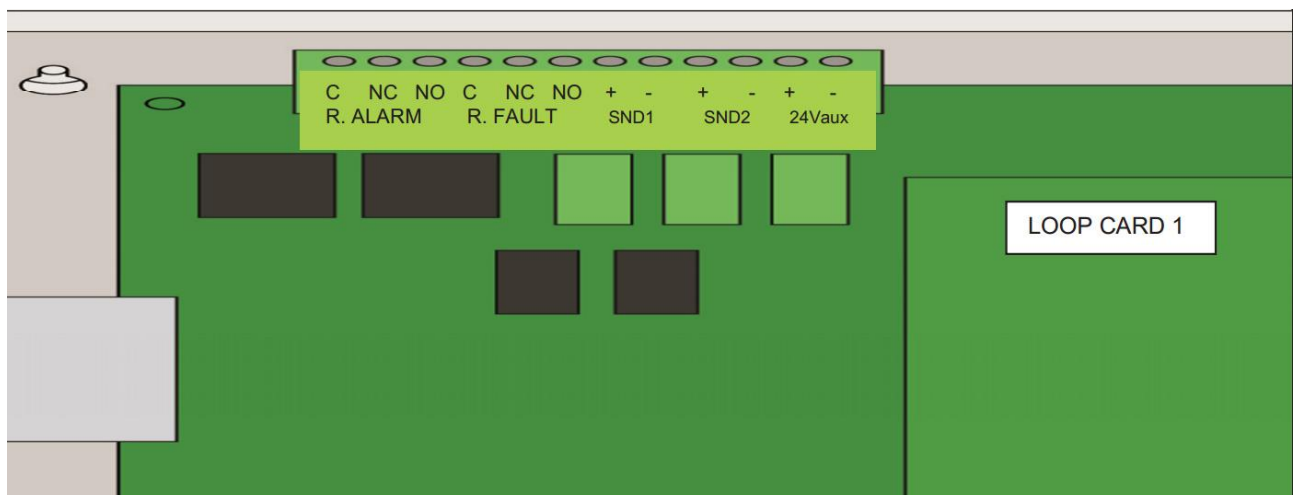

Figure 6: Connections for fire relay, fault relay, conventional sounders and auxiliary DC outputs.

The fire relay (R. ALARM) changes over in any fire condition, and can be used for driving local firefighting equipment such as sprinkler systems, magnetic door holders, air conditioning shut off, auto dialers etc.

NB In the quiescent condition, there is electrical continuity between C and NC. In the fire condition, there is continuity between C and NO.

6.6 FAULT RELAY (VOLTAGE FREE CHANGEOVER CONTACTS)

The fault relay (R. FAULT) is energised in the quiescent condition. When any type of fault occurs, this is indicated by the fault relay to ensure fail safe operation, even in the event of total power loss. That is, the normally open contact will be closed when there is no fault, and open when there is a fault. This should be taken into account when any device is connected to the fault relay.

6.7 AUXILIARY DC OUTPUT

This 24V DC output is provided to support low power requirements (450mA max). A separate power supply will be required for higher current applications.

6.8. FIELD DEVICE TERMINATION

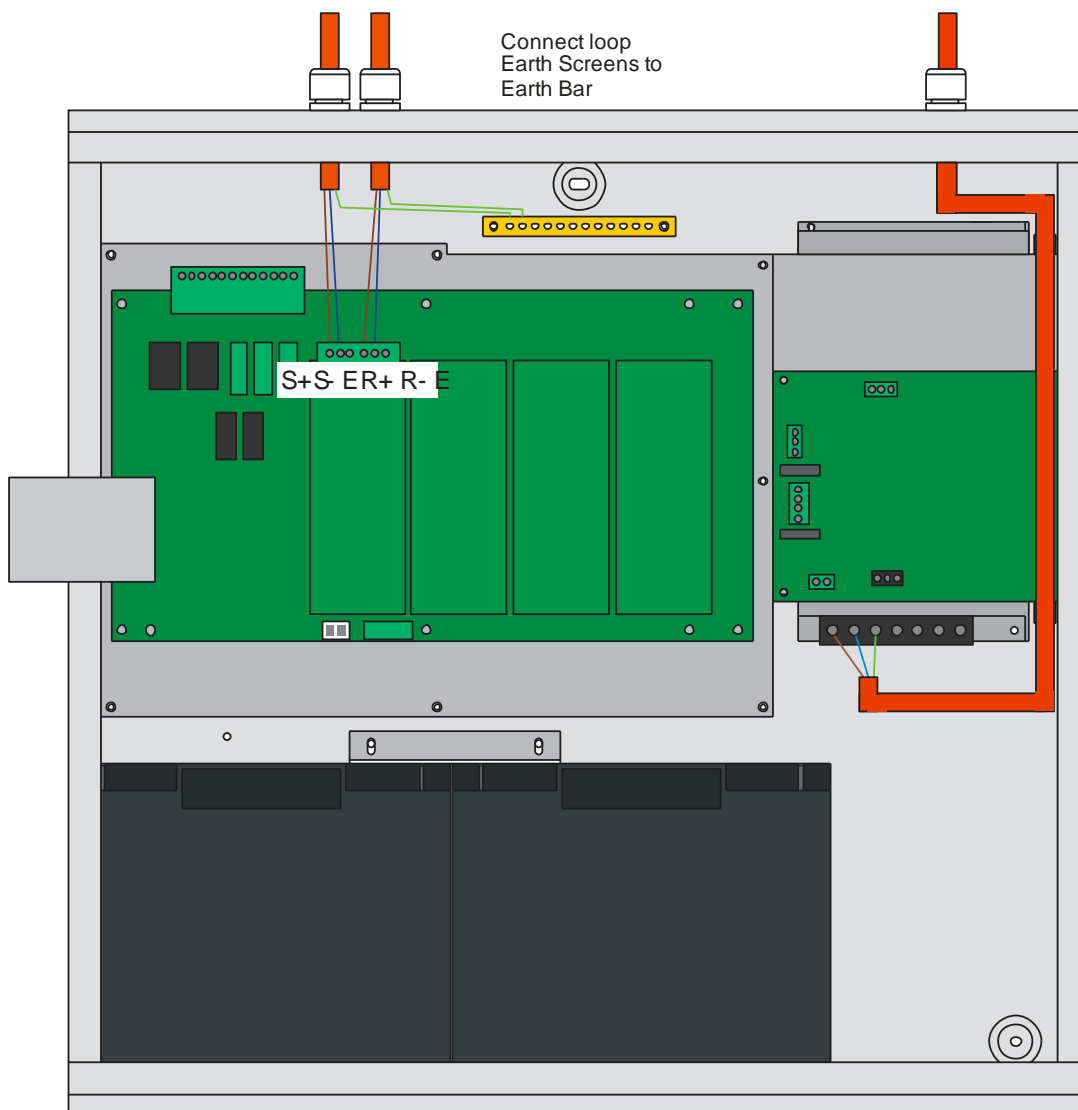

Figure 7: Connecting cables to the Quatro panel

All cables should enter the enclosure via the cable gland, and the cable shields must be connected to the earth bar. Figure 7 illustrates how the mains cable and an addressable loop cable are connected to the panel. All other screens must be terminated at the brass earth strip. **MAKE SURE ANY SPARE ENTRY HOLES ARE COVERED WITH GROMMETS.**

7- PANEL SET UP

7.1 INITIAL PANEL SET UP

The Premier Quarto panel is normally configured ready for installation. But if the panel has been altered (Extra loop cards added for example), then various settings may need to be altered.

7.1.2 POWER SUPPLY

Quatro is normally supplied with an external PSU Charger card. This is the approved PSU CHARGER option. It can also operate with a power supply which is part of the panel's MOTHERBOARD PCB. This is the MOTHERBOARD CHARGER Option. To ensure that the correct fault monitoring is selected, the installer must indicate whether the MOTHERBOARD CHARGER or the PSU CHARGER is being used, as follows:

- Turn the key switch clockwise to the Controls Enabled Position. The controls Active LED will light.
- Press any key followed by the level 2 password (default is 2222)
- Select the option **General**
- Press **ENTER**
- Select the option **Power Supply**
- Toggle between **Motherboard Charger** and **PSU Charger** (using the ▲ and ▼ symbols until the correct mode is displayed).
- Press **F1 (Accept)** to accept the selection, or **F4 (Cancel)** to retain the previous PSU mode.

7.1.3 LOOP MANAGEMENT

The number of loops connected to the panel should be set here.

- Press any key followed by the level 2 password (default is 2222)
- Select the option **Loop**
- Press **ENTER**
- Select the option **Loop Management**
- The panel then displays the 4 loops and whether or not they are installed. Adjust as required.
- Press **F1 (Accept)** to accept the selection, or **F4 (Cancel)** to retain the previous settings.

7.1.4 SETTING TIME AND DATE

- Turn the key switch clockwise to the Controls Enabled Position. The controls Active LED will light.
- Press any key followed by the level 2 password (default is 2222)
- Press the ▼ key until **Date-Time** is highlighted.
- Press the **ENTER** key. The date and time can now be entered using the numeric keypad and the directional keys.
- Press **F1 [Accept]** to accept a new date and time, or **F4 [Cancel]** to leave the date / time unchanged.
- Press **Cancel** or ◀ until the screen shows **SYSTEM NORMAL** or **FAULT**.

7.1.5 CREATING AN INSTALLATION NAME

This can be entered using the PC configuration software. But to enter it manually at the panel:-

Turn the key switch clockwise to the Controls Enabled Position. The controls Active LED will light.

Press any key followed by the level 2 password (default is 2222)

Press the ▼ key until **General** is highlighted. Select **General** then **Installation Name**. You are now able to enter the site reference name of the panel, plus name and telephone number of the installation or Maintenance Company. The site reference name is displayed on the top line of the SYSTEM NORMAL screen, on the left hand side. The name and phone number of the maintenance company will be alternately displayed with any fault condition of the panel.

7.1.6 PASSWORDS

As described earlier in this section, 2 passwords are required to view and set up the configuration on the Quatro panel. These are required to increase the security of a site configuration.

(a) Level 1 or User Passwords (Default 1111)

Authorised users are allowed to view the panel's configuration, status and event logs (see section 16). They can also disable (section 13) and test (section 14) the panel.

Each authorised user can be assigned his own 4-digit Level 1 password by the installation / commissioning engineer. The panel permits up to 31 unique level 1 passwords, i.e. up to 31 people can have their own unique access to Level 1 data. It is recommended that these passwords are assigned during the commissioning of the panel. Changes to these passwords at a later date will require a further site visit by the installation engineer.

The Level 1 password can be changed as follows:

- Turn the key switch clockwise to the Controls Enabled Position. The controls Active LED will light.
- Press any key followed by the level 2 password (default is 2222).
- Press the ▼ key until **General** is highlighted.
- Select **General** and then **Password**. You are now able to enter the password for the 1st authorised user. The LEVEL must be set to 1 (see top right corner).

In the example, the 1st user has been assigned a Password of 4321. There can be up to 31 user numbers, each with a unique Password.

```
CHANGE PASSWORD          LEVEL:    <1>
USER      : [01]
PASSWORD: [4321]
[Accept  ]                [Exit    ]
```

(b) Level 2 or Installer Password (Default 2222)

Only one level 2 password is permitted by the panel at any time. It is essential that the level 2 password is kept secret from the panel users (and of course the general public). This 4-digit password, which the installation engineer can select and edit, is required to set up the site configuration of a panel.

The Level 2 password can be changed as follows:

- Turn the key switch clockwise to the Controls Enabled Position. The controls Active LED will light.
- Press any key followed by the level 2 password (default is 2222).
- Press the ▼ key until **General** is highlighted.
- Select **General** and then **Password**. You are now able to enter the password for the 1st authorised user. The LEVEL must be set to 2 (see top right corner).
- The current Level 2 password must be entered before it can be changed to a new password.

```
CHANGE PASSWORD          LEVEL:  <2>
CURRENT PASSWORD   : [2222]
NEW PASSWORD       : [2468]
[Accept ]          [Exit  ]
```

7.1.7 LED FLASH SETUP

By selecting this function for a specific loop, a device's indicating LED will flash every few seconds.

- Select the option **Loop**
- Press **ENTER**
- Select the option **LED Flash Setup**
- The panel then displays the 4 loops and whether or not they are set to blink. Adjust as required.
- Press **F1 (Accept)** to accept the selection, or **F4 (Cancel)** to retain the previous settings.

7.1.8 ENGINEERING

The loop engineering tool is used to check at what quality the data transfer is on a loop.

- From the installer menu, select the option **LOOP**.
- Select **ENGINEERING**.
- Select which loop you would like to check.
- The quality of the loop will be displayed below the loop selection.

```
LOOP           :<1>
QUALITY       100.0
[Reset  ]          [Exit  ]
```

You should aim to always have your loop quality at 100.0. As the quality of communications decreases, the chance of the system giving out false alarms or faults increases. It can also cause the response from real events to become delayed.

7.1.9 ENABLE USB CONFIG

This will be selected when using the Quatro Configuration Software or Loop Inspector. In order to allow the panel to communicate with a computer via its USB port, carry out the following:

- From the installer menu, select the option **GENERAL**.
- Select **ENABLE USB CONFIG**
- The panel will enter and display the message **USB CONFIGURATION**.
- You can now plug the USB lead into the quatro display board USB port and communicate with the required software.

(Note: When connected to a computer via the display USB port, the Quatro will display an Earth Fault. It should clear when the USB cable is removed.)

7.1.10 PRINTER SETUP

Real Time

If the Quatro panel has a printer fitted, this option is used to select whether the panel prints alarms, or faults or both in real time as they occur. The panel can reprint events over a selectable date range, so the live print can be turned off if this is not convenient.

If a pager system is connected to the Quatro's printer port, then live printing should be selected to allow the messages to be paged.

- From the installer menu, select the option **Printer**
- Press **ENTER**
- Select the option **Real Time**
- The panel then displays whether online printing of alarms & faults are enabled or disabled. Adjust as required.
- Press **F1 (Accept)** to accept the selection, or **F4 (Cancel)** to retain the previous settings.

Print Log

If there is a printer installed, then there is the ability to print a log of faults and events that have occurred from a selected date.

- From the installer menu, select the option **Printer**
- Press **ENTER**
- Select the option **Print Log**
- Enter a date, and the panel will print events from that date to present day.

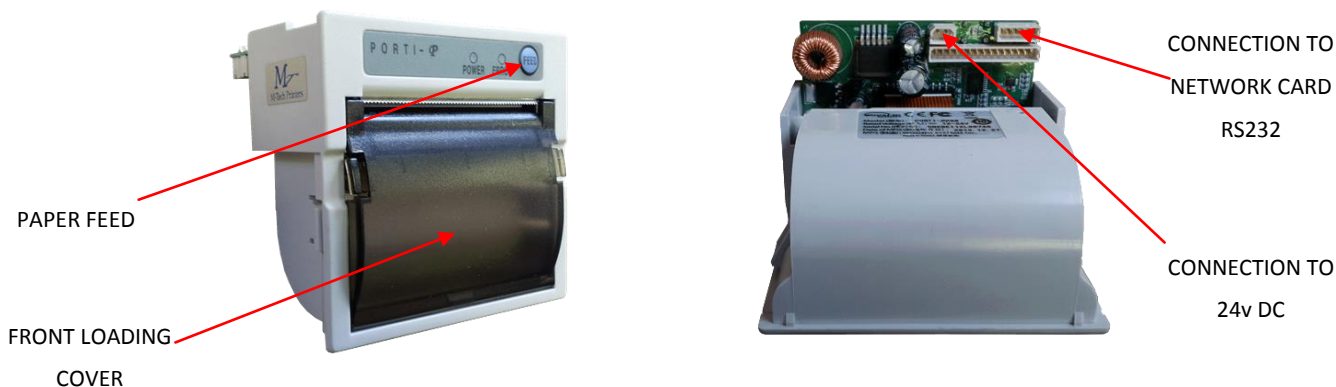

7.1.11 ALARM TONE SETUP

In the Fyreve MKII Protocol, the Quatro allows the alarm tone to be chosen from a list of 16 predefined tones (The panel will be set at a default of TONE 0). The tone is selected on a “per loop” basis, but most installations would require the same tone to be selected on each loop (*This applies to MKII addressable sounders only*).

- From the installer menu, select the option **Loop**
- Press **ENTER**
- Select the option **Alarm Tone Setup**. The panel then displays which tone is selected for each loop. Adjust as required.
- Press **F1 (Accept)** to accept the selection, or **F4 (Cancel)** to retain the previous settings.

7.1.12 FLASHER OPERATION

In the Fyreve MKII Protocol, the Quatro allows the flashers to operate in one of two ways. To turn off when the sounders are silenced or to stay running until the panel is reset. This is selected on a “per loop” basis, but most installations would require the same setting to be selected on each loop (*This applies to MKII addressable flashers and sounder flashers*).

- From the installer menu, select the option **Loop**
- Press **ENTER**
- Select the option **Flasher Operation**
- The panel then displays which setting is selected for each loop (Normal or Until Reset). Adjust as required.
- Press **F1 (Accept)** to accept the selection, or **F4 (Cancel)** to retain the previous settings.

To investigate how the entire menu command structure of the Quatro panel interlinks, refer to Section 18. This illustrates the command structure in a menu tree flowchart of the control keys.

7.1.13 CONFIGURING THE LOOPS

- Turn the key switch clockwise to the Controls Enabled Position. The controls Active LED will light.
- Press any key followed by the level 2 password (default is 2222).

- The display changes to the view indicated in the yellow box to the right. Select **Loop** (by pressing **ENTER** or **✓** or **▶**) and then **Autosearch** and choose Loop No. 1 and Accept (by pressing the **F1** key). The panel searches the chosen loop. After the search has reached 100%, the panel displays the number of valid points (i.e. devices) found, and the number of double addresses (i.e. points with the same address), and the number of addresses that have been modified since the last search.



- Check that the number of **VALID** devices is the same as the number of devices actually installed on the loop. If the panel reports an open or short circuit for a loop, select **Autocheck**. This checks the number of points found when the loop is checked from the start of the loop (S) and then checked from the end of the loop (R). The Start and Return values indicate the position of the loop fault from each end of the loop.

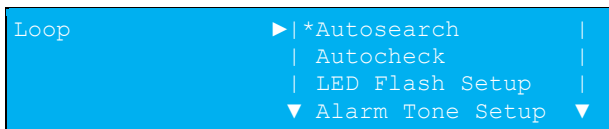

- Loop 1 is now configured. Press **Accept** and then repeat the operations above for the remainder of the loops fitted to the panel.
- Press **Accept** then **Cancel** then the **◀** key until the screen either shows **SYSTEM NORMAL** or **FAULT**. The panel will now function as a basic system.

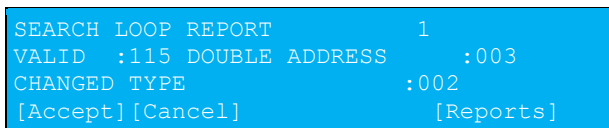

7.1.14 ZONE LABELS

The subdivision of a fire alarm system was explained in Section 3, the Premier Quatro panel being capable of assigning 20 zones. When a fire is enunciated, the zone number in which the fire is located is indicated on the alphanumeric display. In addition to its numerical description, a zone can be identified by a text label, e.g. 3RD FLOOR WEST EXT. If the installer associates a text label with each zone of a fire alarm system, this will be displayed on the LCD when a fire is detected. The maximum length of the zone text label is 18 characters.

To access the menu for selecting Zone Labels:

- Turn the key switch clockwise to the Controls Enabled Position. The controls Active LED will light.
- Press any key followed by the level 2 password (default is 2222).

Select Zone edit, and then the zone number by either using the alphanumeric keypad, or the function keys F1 or F2 to increment or decrement the zone number. Type in the text label between the brackets on the 3rd line of the display. Selecting F3 allows one or more points (i.e. devices) to be added to the loop.

```
ZONE EDIT
ZONE :<XXX>   MODE       ENABLE
TEXT  :[3RD FLOOR WEST EXT   ]
        [ - ]      [ + ]      [Points]      [Exit]
```

```
ADD POINTS
ZONE : <XXX>           LOOP : [1]
RANGE : [001]         TO   : [001]
[Accept ]                [Exit  ]
```

The LCD also indicates the current mode of each zone – enabled or disabled.

7.1.15 ADDRESS LABELS AND ZONES

Premier Quatro is an addressable panel, i.e. it will indicate the address or location of a fire that has been detected. The address number of each point or device on each loop has already been selected according to its DIP switch setting. The installation engineer must now assign a label or location for each device, e.g. ROOM 107. A maximum of 20 characters can be used for each label. At the same time each point can be allocated to a zone.

To access the menu for selecting Address Labels:

- Turn the key switch clockwise to the Controls Enabled Position. The controls Active LED will light.
- Press any key followed by the Password 2222.
- Select **Points** followed by **Edit Point**. For each point the following data can be entered:

Loop Number, Address Number, Zone Number & the Text Label (e.g. ROOM 107)

The LCD also indicates the MODE of a point, i.e. ENABLED or DISABLED, the analogue value (V) that the device is sending to the panel, and the type. Pressing the F keys below [-] and [+], decreases or increases the address number.

```
LOOP :<1>      ADR  : [019]   ZONE:[023]
TYPE :MCP     MODE :ENABLE   V:192
TEXT  :[ROOM 107   ]
        [ - ]      [ + ]      [Exit  ]
```

When a fire is detected, the address label of the device which has been triggered can be displayed by using the keys ► and ◀ to scroll through the list of fires detected and stored by the panel.

7.1.16 PLATFORM SOUNDER (SANDWICH SOUNDER)

The remote output on a detector is used to switch on a connected remote indicator (LED). It can also be used to trigger a “platform sounder”

A panel cannot see a platform sounder as it does not communicate with the panel, so the panel needs to be told that the sounder is fitted.

- Turn the key switch clockwise to the Controls Enabled Position. The controls Active LED will light.
- Press any key followed by the level 2 password (default 2222).
- Select **Point** followed by **LED Setup**. Change Platform sounder field from NO to **YES**.

(NOTE: It is recommended that all detectors that do **NOT** have a platform sounder fitted are to have it set as **Platform Sounder: NO.**)

```
LOOP :<1> ADR  : [002] TYPE :MKII-AOH
PLATFORM SOUNDE: [YES]
        [ - ]      [ + ]      [Exit  ]
```

7.1.17 VIEWING DEVICE STATUS

To view the status of any loop device (point):

- Turn the key switch clockwise to the Controls Enabled Position. The controls Active LED will light.
- Press any key followed by the level 1 password (1111 is the default).
- Next select Point from the menu, followed by Show. The information displayed is: - Loop, address, zone, point type, mode, analogue value & text label.

NB the same parameters are displayed as in Section 11.7 (Address Labels and Zones). However, Level 1 password control does not allow the zone number and address label to be changed.

For detectors, V is usually about 72 for clean air and 160 during alarm. Non analogue devices such as call points and I/O Units have a normal value of 72, and an alarm value of 192. They will return a value of less than 16 to report a fault condition.

Some of the text labels displayed for each addressable point are:

ZAIO-MI, ZAI-MI, ZAZM-M, MKII-AOP, MKII-AOH, MKII-AHF, MKII-AHR and MCP. Each of these is known as the TYPE of a point or device. (NOTE: A SMM/B will have the text label MKII-AOP)

ZAZM-M is an abbreviation for Zone Monitor Unit, for interfacing conventional detectors or call points to the loop. MKII-AOP is a combined optical and heat detector. MKII-AHF is a fixed temperature heat detector and MKII-AHR is a rate of rise heat detector.

```

LOOP :<1>      ADR  : [105]      ZONE: 016
TYPE  :OPT-STD  MODE  :ENABLE    V:072
TEXT  :RESTAURANT 2ND FLOOR
        [ - ]      [ + ]      [Exit ]
  
```

7.1.18 LOCATE OR VERIFY A DEVICE

It is possible to send commands to individual devices to turn on their alarm LED. This can be a very useful function when it's required to locate a device or verify its address (This is also a good way of tracking down double addresses).

- Turn the key switch clockwise to the Controls Enabled Position. The controls Active LED will light.
- Press any key followed by the level 2 password (default 2222).
- Select **Points** followed by **Toggle LED**. Select the loop and address of the point to be checked.

```

LOOP :<1>      ADR  : [002]      ZONE: 001
TYPE  :I/O STD  MODE  :ENABLE
TEXT  :3RD FLOOR WEST HALLWAY
        [ - ]      [ + ]      [Exit ]
  
```

The [-] and [+] commands can be used to decrement or increment the address of the point being searched for. If the device has a panel controlled alarm LED it will be turned on immediately its address is selected. Scrolling to another device or exiting the menu will automatically turn the LED off.

8- NETWORKING

8.1 NETWORKING INTRODUCTION

Up to 32 control panels (CIEs) and /or repeater panels can be connected together, i.e. networked. The maximum distance between nodes is 1 km (providing the correct data cable is used). To set up a network of panels, each panel must be fitted with a network card. The RS485 terminals on the network card are used to connect one or two other panels, using the same type of fire resistant cable with which the fire devices are connected to each panel. So each panel has one input connector and one output connector. The network can be configured with a ring or bus topology.

8.2 RING NETWORK

In a ring network, each control panel is connected to other control panels to form a ring. This has the same topology as the loops of addressable devices connected to each CIE. This has the advantage that no panels are lost if there is a single break in the network.

It is recommended to always network panels in this topology.

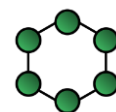

8.3 BUS NETWORK

This is the same as a ring network but wired panel to panel without a return connection from last panel to first panel. It could also be referred to as a radial or spur network. At the final panel in the network, only the input connector is used.

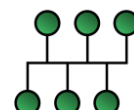

8.4 CONFIGURING THE NETWORK

There are 3 types of network card available for the Premier Quatro Panel.

OLD STANDARD NETWORK CARD

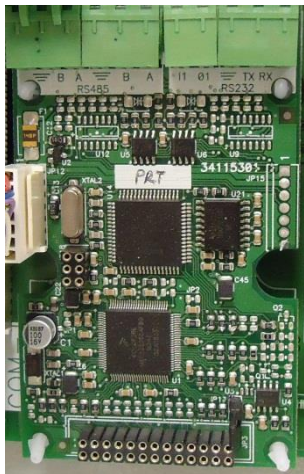

The Standard Network Card provides an RS485 repeater connection, and an RS232 Printer connection.

NEW MODBUS NETWORK CARD



The Modbus Network Card has an RS485 repeater connection, an RS232 printer connection and a Modbus serial communications protocol connection.

GATEWAY NETWORK CARD



The Gateway Network Card has an RS485 repeater connection and a TCP/IP Interface for connection to the Data log Alarm Manager Software.

What can our network do?

- RS 485 repeater output
- Serial port for either panel printer or external printer (desk top)
- RS 485 network connection for use with standard network data cable
- Modbus interface and graphical software connection via RS485
- Ability to send key events from (reset, sounders on/off, mute) one panel to another
- Mirrors the status of all panels in the network (LCD and fault, alarm & zone LED's)
- Remote cause & effect to make any kind of action from one panel to another
- Ability to auto-reconfigure if any network problems occur (missing node)
- It is tolerant to one fault on the line if it has been wired as a ring.
- Up to 32 nodes in either a bus or ring topology. One node is to be set controller (master) of the network

From the Installer menu, select Network. There are 6 sub-menus:

Node Setup

From here you select whether this node is the controller, or just a normal node. You also assign a network address (Node number). There should always be just only one node set as controller on the network.

Network Filter

This determines whether this node reports all network events, or just those from a specific network address.

Node search

This should be performed from the controller panel. The panel configures the network and displays the results. The 3 possible configurations are:-

Ring – All nodes are connected as a ring (Recommended configuration). As there are 2 paths to each node, the system will tolerate a break in any of the network cables. It also reports the number of nodes found.

Bus – The nodes are daisy-chained together, with no return from the last node to the first. Here a single cable break would disrupt the network. It also reports the number of nodes found, as well as the Network address of the first and last device on the line.

Isolated – There are no other nodes on the network. (This would be the situation if the network card is used for the printer output, for example).

Note: a STAR or MESH topology is not allowed.

Version

This will display the current firmware version of the network card.

View Current Topology

Shows the last configured network topology (Will show which of the three configurations the panel was last networked it, as described above).

Shared Zones

These settings can be configured to allow the panel Zone LEDs to be shared across the network.

Gateway Network Card

The gateway network card also has a screen to configure its TCP/IP settings. It is accessed by pressing F2 on the Node Setup screen. It has options for setting the gateway cards TCP-IP address, the default gateway address, and the subnet mask.

These should be set up to allow the host PC to communicate with the panel. Consult the building network administrator for suitable settings.

8.5 MODBUS

What is the Modbus Protocol?

MODBUS is a standard communication protocol used in a wide range of industrial equipment. It allows the connection of multiple devices, in a master/slave topology. Multiple slaves can share the same bus, but only one master can be in the line at the same time. Master can communicate with a specific device (peer to peer) or with broadcast frames.

Modbus defines the communication format, including command, data and checksum.

Quatro Modbus uses RTU frames. These frames use silences of 3.5 chars, and a CRC of 16 bits. Data size is 8 bits.

Quatro Modbus system accepts reading (0x04) and writing (0x10) commands. These commands bits affect 16-bits registers.

What registers can the Modbus read?**General information registers**

These registers contain general panel information, like software versions and type of panel.

- Modbus state
- Type of panel
- Panel version
- Network version
- Modbus version

Panel status registers

These registers are used to get panel current status. It also includes virtual keys to interact remotely from the panel.

- Panel status
- Fault information
- Alarm information
- Virtual key registers
- Power status
- PCB Sounder 1& 2 Status
- Fault Relay
- Alarm Relay
- Number of faults in panel
- Number of alarms in panel

Loop status registers

Following registers contain loop status

- Loop status (1-8)

Network status registers

These registers will contain the status of the network of Quatro addressable panels.

- Node configuration
- Network status
- Network topology

Zone status registers

These registers contain the zones status.

- Zone status (1-250)

Device status registers

These registers contain the status of all devices. One loop contains up to 250 devices.

- Loop 1-8 device statuses (Devices 1-250)

(FOR MORE INFORMATION ON USING THE MODBUS, PLEASE REFER TO THE 'MODBUS REGISTERS MANUAL' - Doc No. GLT-256-7-2)

8.6 REPEATER PANEL

The Repeater Panel is used to remotely indicate the status of all CIE's that are connected on the same network. The general fire and fault LED indications are repeated on the Repeater Panel. An alphanumeric display provides further fire / fault data. The Repeater also has its own control buttons to reset the CIE, start the sounders, stop the sounders, and silence all buzzers in the network.

For further information about the Repeater Panel, and how to connect it and other Quatro CIEs onto the network, refer to the Quatro Repeater Panel installation manual (GLT.MAN-143).



9- PROGRAMMING

9.1 CAUSE AND EFFECT

9.1.1 ACTIONS

The Premier Quatro system has very comprehensive Cause and Effect capabilities (known in the panel menu as Actions).

The Default factory configuration is that any alarm will activate all outputs on the panel.

Like most addressable systems, the panel allows comprehensive programming of the sounder outputs. It is the responsibility of the commissioning engineer to verify that the programmed panel actions operate the sounders as required.

Any input (or cause) can generate any output (or effect). For example, if the input is a fire in zone 1 (e.g. an optical detector triggered by smoke), the system can be programmed to generate output(s) (e.g. operate one or more sounders or relay outputs in one or more zones).

The inputs and outputs can be selected from 4 categories – Point, Zone, Loop and Panel.

Example of Selecting a Cause & Effect (New Action)

The following example shows ACTION No. 5 (top right of LCD) being selected. A fire (input) in Zone 1 is programmed to have the effect of activating the sounders in Zones 1, 2 and 3. In addition, the activation of the sounders is delayed by 30 seconds after the fire has been detected.

- Select Input Category: **Zone**

```

ACTION CREATION                                0005
      INPUT SELECTION
[Point  ] [Zone  ] [Loop  ] [Panel  ]
    
```

- Select Range of Zones: **001**
- Select Type of Input: **General Alarm**

```

ZONE SELECTION                                0005
RANGE:<001>          TO      [001]
[Gen Alarm  ] [More  ] [Cancel ]
    
```

(General Alarm, detector alarm, MCP alarm, multiple point alarm, or fault. By selecting [More] the operator can choose from one of these 5. For example, if MCP alarm is chosen, the Cause & Effect will only apply to alarms from MCP's in Zone 1, and will ignore all other alarms in Zone 1. If DET alarm is chosen, the Cause & Effect will only apply to a detector alarm in Zone 1, and will ignore all other alarms in Zone 1. Multiple point alarm means that at least 2 points / devices in Zone 1 must be activated before the programmed Effects occur. The Fault option will trigger cause & effects if there is a fault in Zone 1 NOTE: If a zone range is selected for Multi.Pt Alarm, it will set up a multi-point alarm in each zone within the range. The panel will only trigger the cause & effect if any zone in that range has 2 devices in alarm. If 1 device in a zone goes into alarm, and another 1 device in a DIFFERENT zone goes into alarm, the cause & effect will not be triggered. It has to be 2 devices from the SAME zone.

- Select Output Category: Zone
- Select Remote (RMT) Event & Panel No. - This is used when the panel being configured (e.g. 0001) is networked to 1 or more other panels (e.g. 0002), causing the outputs of 0002 to operate according to the 0002 panel's configuration, when there is a fire in the 0001 panel.

```

OUTPUT SELECTION                                0005
RMT EVENT :<YES>    PANEL      : [0002]
[Point  ] [Zone  ] [Loop  ] [Panel  ]
    
```

- Select Range: **Zones 1 – 3**
- Select Delay: **30** seconds
- Select Type of O/P: **Sounders ON**

```

ZONE SELECTION                                0005
RANGE:<001>          TO      : [003]
DELAY      : [030]    TONE   : [ALARM FL]
[Sounders ON ] [More  ] [Cancel ]
    
```

(NB other types of output are: Switch off all sounders, switch on all outputs, switch off all outputs, switch on all relays & switch off all relays).

The 4 digit number in the top right of each display is the Action Number. If more than one action is chosen, then ACTION 0001 will be executed first, then ACTION 0002, and then ACTION 0003, and so on. However, because the time taken to perform each action is very small, it will appear to user that all actions occur simultaneously. Be careful when configuring the panel that there are no unintentional conflicts between the ACTIONS.

If required, it is possible to delay the execution of one or more of the ACTIONS. This is done through the output parameter DELAY (000 to 600 seconds).

ACTIONS can be modified later by selecting Modify from the Actions menu. For example:

Modify Action Number 5. Total Actions 10.
 Input: Panel – General Alarm.
 Output: Zone – Range 1 to 3 with Outputs ON.
The * means that the Output includes a RMT Event.

```
ACTION MODIFICATION <0005>:001 DLY:010
I Panel          Gen Alarm
O Zone RANGE 001 To 003 Outputs ON*
[Input  ][Output ][Erase  ][Exit  ]
```

The current action (i.e. 0005) can be erased by selecting the [Erase] command. In this case, actions 0006 to 0010 will then be automatically re-numbered as actions 0005 to 0009. See also the Menu Command Structure in Section 18.

9.1.2 LOGIC

Logic events are very similar to that of the Actions. The difference is that with Logic you are able to create “AND” statement events with specific Points, Zones, Loops and Panels, where in Actions it does not allow you to do this. For example, if the input is a fire in zone 2 (e.g. an optical detector gone into alarm), the system can be programmed to wait until it receives another fire indication from a device, before it sets off its output devices. As with actions, it is the responsibility of the commissioning engineer to verify that the programmed panel logics operate the sounders as required. The inputs and outputs can be selected from 4 categories – Point, Zone, Loop and Panel. Example of Selecting a Logic Event (New Logic):

The following example shows LOGIC No.2 (top right of LCD) being selected. The Quatro is programmed to only activate the panel sounders (with a 10 second delay), when points address 7 & 8 on loop 1 detect a fire.

This will be to setup the 1st event:

- Select Num of Events: **2** (MAX 10 EVENTS)
- Select Input Category: **Point**
-

```
ACTION CREATION                                0002
          NUM OF EVENTS
          <02>
[Point  ][Zone  ][Loop  ][Panel  ]
```

- Select Loop: **1**
- Select Point Address: **007**
- Select Type of Input: **Alarm**

```
POINT SELECTION                                0002
LOOP : <1>          ADR : [007]
[Alarm  ]          [Cancel ]
```

This will be to setup the 2nd event:

- Select Input Category: **Point**

```
ACTION CREATION                                0002
          INPUT SELECTION
[Point  ][Zone  ][Loop  ][Panel  ]
```

- Select Loop: **1**
- Select Point Address: **008**
- Select Type of Input: **Alarm**

```
POINT SELECTION                                0002
LOOP : <1>          ADR : [008]
[Alarm  ]          [Cancel ]
```

This will be to setup the output:

- Select Output Category: **Panel**

```
OUTPUT SELECTION                                0002
RMT EVENT : <NO>
[Point  ][Zone  ][Loop  ][Panel  ]
```

- Select Delay: **010** seconds
- Press **More** to select output type: **Sounders ON**
- Select Sounder Tone: **ALARM FLASH**
- Press **Sounders ON**

```
PANEL SELECTION                                0002
DELAY : <010>
TONE : [ALARM FLASH ]
[Sounders ON ] [More ] [Cancel ]
```

The current action (i.e. 0005) can be modified by selecting the **MODIFY LOGIC** option in the Actions menu, and its used the same way as described above in the modify actions (section 17.2). They can also be erased in this same menu by selecting the **ERASE** option.

9.1.3 CLASS CHANGE

If it is required to configure an I/O to act as a class change input then it can be enabled by:

- Enter the **Actions** menu via the Installer menu (2222 password).
- Select **Class Change** and press **ENTER**
- Press **▼** to select **Enable**.
- Enter the required I/O device by entering the correct loop and address numbers.
- Press **F1** to accept.

9.1.4 DISABLE RELAYS

If it is required to configure an I/O to disable all relay outputs then it can be enabled by:

- Enter the **Actions** menu via the Installer menu (2222 password).
- Select **Disable Relays** and press **ENTER**
- Press **▼** to select **Enable**.
- Enter the required I/O device by entering the correct loop and address numbers.
- Press **F1** to accept.

9.1.5 DISABLE OUTPUTS

If it is required to configure an I/O to disable sounders & relays then it can be enabled by:

- Enter the **Actions** menu via the Installer menu (2222 password).
- Select **Disable Outputs** and press **ENTER**
- Press **▼** to select **Enable**.
- Enter the required I/O device by entering the correct loop and address numbers.
- Press **F1** to accept.

9.1.6 DAY & NIGHT MODE

This feature will give the installer the ability to turn off delays at night, and setup an investigation delay timer during the day. It can be enabled by:

- Enter the **General** menu via the installer menu (2222 password).
- Select **Two Stage Delay** and **Disable Delay** and change them both to **Yes** and press **Next** to confirm.
- You are now able to select from what time and day to have the mode activated. (The time selected will choose when the **DAY MODE** will be active; when the day mode is inactive the **NIGHT** mode will take over.) Once these settings have been selected, press **Next** to confirm.
- Select the zone range to have the two stage delays apply too, and for how many seconds Delay 1 & 2 will last. Press **Select** and return the home screen. If the mode has been successfully set up then either **Night Mode** or **Day Mode** shall be displayed.

When using Day & Night mode it is important to remember the following useful information:

- When in Delay 1, you can only start Delay 2 after the panel buzzer has been silenced.
- When in Delay 2 you can increase the delay timer by 30 seconds if needed by pressing the **Increase Delay** button (F1). The panel has the ability to increase the delay too over 9999 seconds; although following BSI Standard EN54-2 it's only recommended that a delay is only ever set too 600 seconds max.
- When in Delay 1 or 2 you can end the delay at any time by pressing the **End Delay** button (F4).
- If two devices in a DIFFERENT or the SAME zone go into fire, then the panel will override the delays and go into fire.

9.1.7 OUTPUTS AND DELAYS

Following the indication of a fire, the panel will activate outputs (i.e. sounders and / or relays) according to the cause and effect rules or ACTIONS that have been programmed (see Section 17). In certain circumstances, the activation of outputs may be delayed whilst the fire is being investigated.

(a) Sounder Delays

If the operation of sounders has been delayed in one or more of the programmed **ACTIONS**, then this will be indicated by the illumination of the **DELAY ON LED** (in the **SOUNDER STATUS** section of LEDs). During a fire alarm it is possible to override all the sounder delays (at any access level) by pressing button **F4**, which is labelled [END DELAY], as shown.

The [END DELAY] label is erased from the display when either the longest sounder delay has expired or the sounder delay has been overridden by pressing **F4**.

```

FIRST ALARM:  Z001 - FIRST FLOOR
LAST ALARM :  Z003 - THIRD FLOOR
ZONES IN FIRE :002 POINTS IN FIRE :002
PRESS < OR > TO SCROLL      [END DELAY ]
    
```

(b) Relay Output Delays

Relay outputs can also be delayed via the cause and effect actions. In this case, no LED is lit to indicate a delay (since this type of output is not mandatory).

NOTE: It is possible to toggle delays on & off via the user menu. If the delay is not working as expected, check in the user menu if the delays have been turned off. (If there are delays to sounders, the sounder delay LED will be lit when the delays are enabled. Delays to relays do not turn on this LED)

(c) Removing/Disable Delays

If it is required to remove a delay, then it can be done by going into the **Installer menu ▶ Actions ▶ Modify** then select the action which you wish to erase. You can also edit a delay in this same location by pressing **Output** and changing the delay time as required.

If a user needs to disable all current delays that are on the panel, then this can be done by entering the **User menu ▶ Delays ▶ Disable**. To re-enable the delays, repeat this process. (**IMPORTANT:** After the delays have been re-enabled, return to the System Normal screen and press RESET to ensure that the panel has correctly re-enabled the delays. *The Delays LED should come back on.*)

9.2 CONFIGURATION SOFTWARE

The Quatro Configuration Software is an easy yet powerful tool for programming the Quatro range of panels. There is no special programming leads required to connect to the panel, just a standard USB A-B lead (the type used on printers) It consists of three main screens:

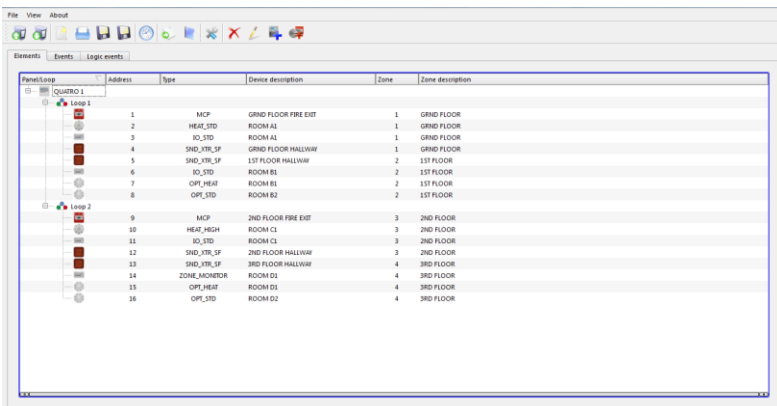

Editor Screen

This screen allows the engineer to easily add and edit text information for the point locations and also the zones.

It also allows for the changing of zones and the manual adding of panels, devices or sounders.

Cause and Effect Screen

The cause and effects are created by simply clicking on the input and then dragging it to the required output. You also have the ability to change event type, action settings, add delays and to also tell the output device whether to activate or to shut down after a delay.

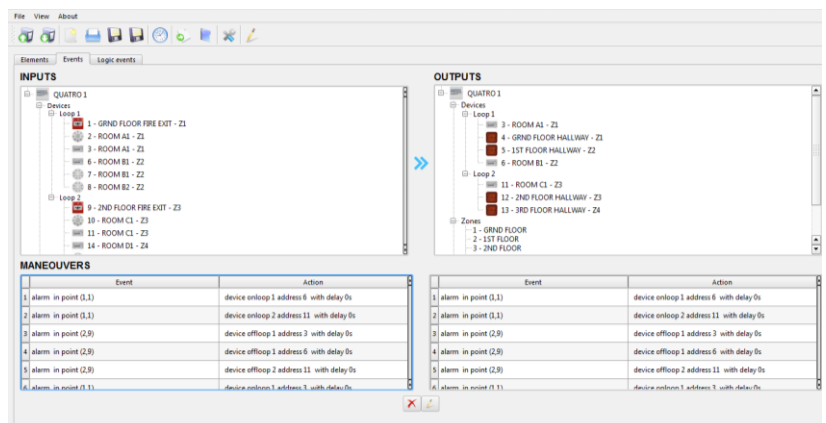

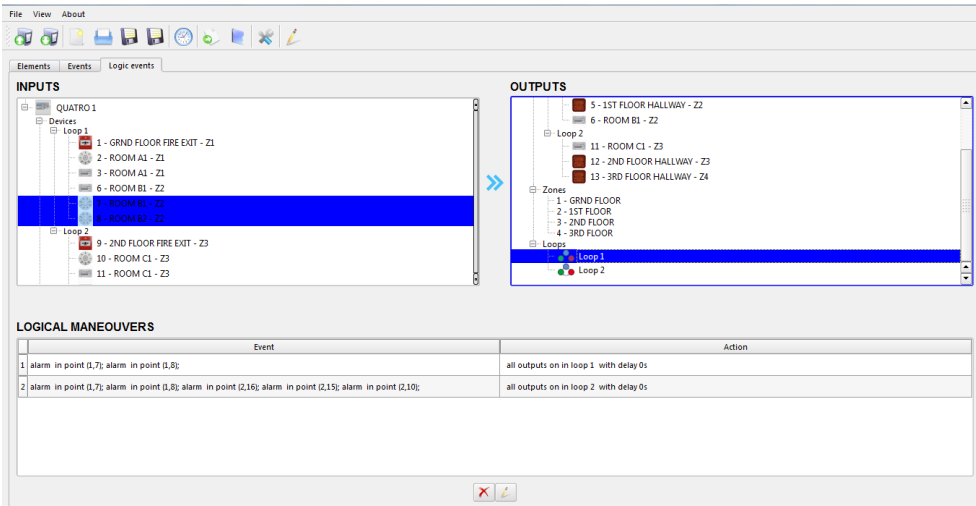

Logic Events Screen

The logic events can be created the same way by simply clicking on the inputs and then dragging it to the required output. Same with cause and affects you have the ability to change event type, action settings, add delays and to also tell the output device whether to active or shut down after a delay. You can also change the number of events needed for the panel to go into alarm.

Additional Features

The software also allows for the download of event logs, and to print off loop and cause and effect information.

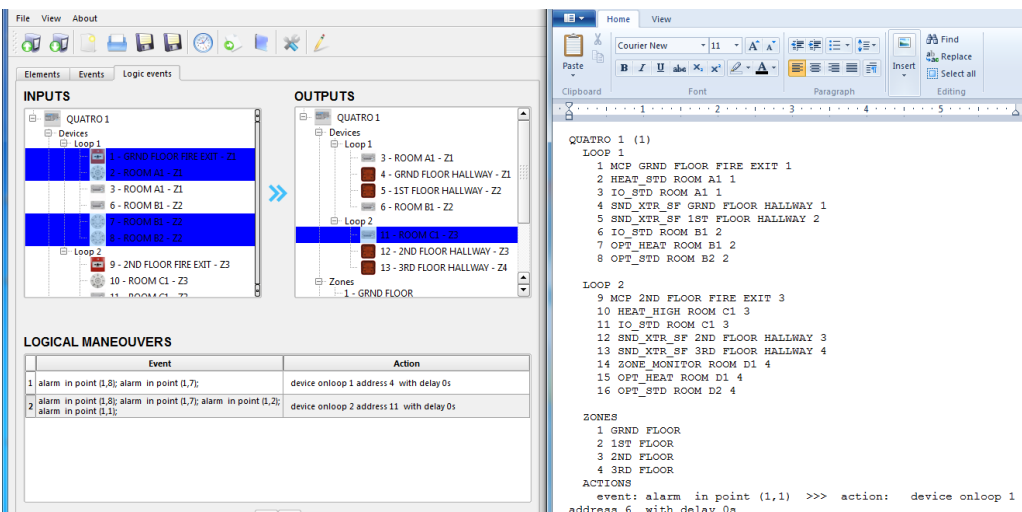
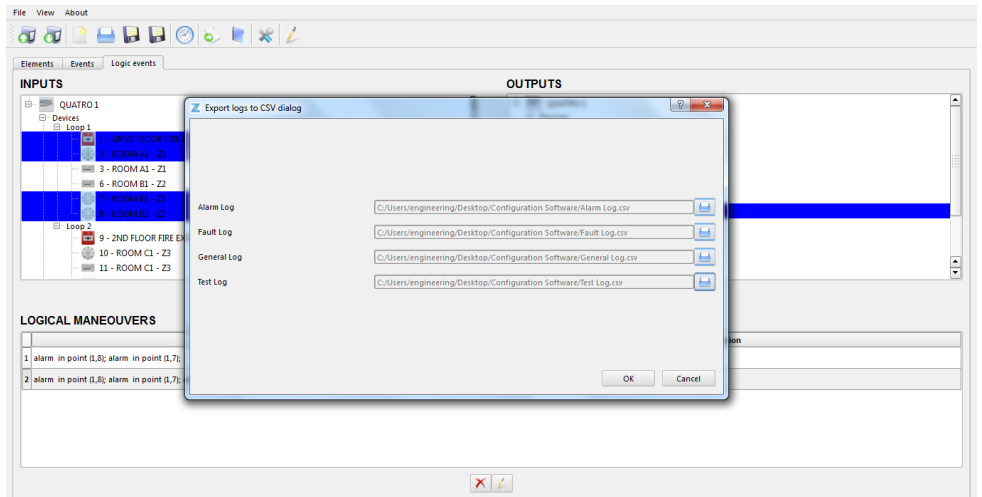

10- MENU COMMAND STRUCTURE

This section summarises the complete command structure of the Quatro panel. Various functions can be accessed at different levels within the panel, the **NO ACCESS** level, the **CONTROLS ACTIVE** level, the **USER** level, and the **INSTALLER** level.

At the **NO ACCESS** level (where the black controls key is switched OFF), the basic status of the panel is indicated by its LEDs and alphanumeric display (LCD). An overview of any fires fault, disablement and test condition can all be observed at this level. An audible warning is also given when a new event occurs. With one exception all the keys (i.e. front door buttons) are inactive at this level. The exception occurs when a delay to the fire alarm outputs (sounders etc.) has been selected by the installation engineer. In this case, when a fire alarm is indicated, **[END DELAY]** is displayed above key **F4**. Pressing **F4** causes the outputs to be activated immediately.

At the **CONTROLS ACTIVE** level, the following controls are active:

START/STOP SOUNDERS, SILENCE BUZZER, RESET, the ► and ◀ keys to scroll faults and fires, the F keys to display faults during a fire alarm and scroll between information on the main screen during disablements and test conditions, and the numeric keys to change a password.

At the **USER** level, the user can also access the information shown below in Section 18.1, by entering his / her unique level 1 password

10.1 USER LEVEL (LEVEL 1)

Default Password 1111

PRIMARY SELECTION	SECONDARY SELECTION	COMMENT
Zones	Show	Displays zone details
	Show En. Zones	Indicates enabled zones
	Show Dis. Zones	Indicates disabled zones
	Show Test Zones	Displays zones in test mode
	Enable	Enables zones in range x to y
	Disable	Disables zones in range x to y
Point	Test	Zones in range x to y are changed to test mode & enables / disables sounders in zones in test mode
	Show	Shows loop, address, zone, type, mode, analogue value, text for each point
	Show Dis. Points	Indicates disabled points
	Enable	Enables points in range x to y
Relays	Disable	Disables points in range x to y
	Enable All	Enables all relays
	Disable All	Disables all relays
	Enable by Zone	Enables relays in zones x to y
	Disable by Zone	Disables relays in zones x to y
	PCB outputs	Enable / Disable Alarm relay and /or Fault relay on Terminations PCB
Sounders	Show	Shows the number of Enabled & Disabled Relays
	Enable All	Enables all sounders
	Disable All	Disables all sounders
	Enable by Zone	Enables sounder by zone (or range of zones)
	Disable by Zone	Disables sounder by zone (or range of zones)
Logs	PCB outputs	Enable / Disable PCB sounder 1 and/or 2
	Show	Shows the number of Sounders
	Faults	Event No Date/Time Event Panel No/Loop No/Addr Zone (if applicable) Text (if applicable)
	Alarms	Event No Date/Time Event Panel No/Loop No/Addr Zone (if applicable) Text (if applicable)
	Test	Event No Date/Time Event Panel No/Loop No/Addr Zone (if applicable) Text (if applicable)
Delays	All	Event No Date/Time Event Panel No/Loop No/Addr Zone (if applicable) Text (if applicable)
	Delay On/Off	Switches delay on/off which has been selected at AL3
Test LED & LCD		All LEDs and LCD pixels active. Buzzer activated

The installation engineer has to access the information in Section 10.2 by entering the unique level 2 password.

10.2 INSTALLER LEVEL (LEVEL 2)

Default Password 2222

PRIMARY SELECTION	SECONDARY SELECTION	TERTIARY SELECTION OR COMMENT
Loop	Autosearch	Searches for all devices on specified loop & displays: VALID: xxx DOUBLE ADDRESS: xxx MODIFIED TYPE: xxx
	Autosearch/ Reports	Lists the quantity of each type of device found
	Autosearch/ Addresses	Address Map
	Autocheck	Checks from start of loop (S) & then end of loop (R). Displays no. of devices seen from each end of loop
	LED Flash Setup	Device LEDs flash every 2s, (selected per loop)
	Alarm Tone set up	Select 1 of 16 alarm tones to operate during alarm.
	Loop Management	Selects which loops are fitted to the panel
	Flasher Operation	Select whether flashers run until silence or until reset on a per loop basis
	Engineering	Displays the communication quality for each loop
Zones	Zone edit	Edits zone text label & adds points to zone xxx in loop y
	AutoAssign points	Assigns points to zones automatically. 25 devices per zone
	Add point	Adds points to zone xxx in loop y
Points	Edit Point	Displays type, mode, analog value & text for each point, & allows text to be edited
	LED Setup	Sets the operation of the MKII detector flashing LEDs, and determines if a platform sounder (sandwich sounder) is fitted
	Toggle LED	Activates LED selected point to locate devices on a loop
Actions	New	Add a new cause & effect action. See Section 9.1
	Modify	Modify an existing Action
	New Logic	Add a new logic event action. See section 9.1.2
	Modify Logic	Modify an existing logic action.
	Class Change	Configure an I/O to act as a class change input
	Disable relays	Configure an I/O to disable all relay outputs
	Disable outputs	Configure an I/O to disable sounders & relays.
Logs	Faults	Event No Date/Time Event Panel No/Loop No/Addr Zone (if applicable) Text (if applicable)
	Alarms	Event No Date/Time Event Panel No/Loop No/Addr Zone (if applicable) Text (if applicable)
	Test	Event No Date/Time Event Panel No/Loop No/Addr Zone (if applicable) Text (if applicable)
	All	Event No Date/Time Event Panel No/Loop No/Addr Zone (if applicable) Text (if applicable)
	Erase	Erase Log (Yes / No)
General	Installation Name	Reference Maintenance Phone
	Language	English / Espanyol/ Portugese / Francais / Hungarian / Italian / Lietuviu / Nederlands
	Passwords	Level 1 Range 1 to 31 Password xxxx Level 2 Current Password New Password
	Power supply	PSU Charger Motherboard Charger
	Disable Buzzer	Used to disable the panel buzzer during commissioning & maintenance (F2 to bring up screen to toggle off LCD monitoring - for older PCBs)
	Day-Night	Allows the installer to turn off delays at night time, and or disable relay outputs during the day.
	Delayed Mode	Two stage delay. Allows the user to set a short initial delay, followed by a longer investigation delay.

	Check version	Panel s/w version & s/w versions of each loop card
	SW Upgrade	Enables an authorised engineer to upgrade the Quatro software, using PC software
	Enable USB Config	From F/W V 1.77 onwards, the panel must be put into USB access Mode before the panel will communicate with the PC software.
Network	Node Setup	Address & Node Type per Panel (Also TCP/IP settings for Gateway Network card)
	Network Filter	All / Selective Listen Address of Repeater Panel
	Node search	Finds & configures all network nodes.
	Version	Displays firmware version of the network card
	View Current topology	Shows the last configured network topology
	Shared zones	Allows Zone LEDs to be shared across the network
Printer	Real Time	Chose if Alarm and/or Fault events are printed in real time
	Print Log	Select a date to print events from that date to present day
Date-Time	Date xx:xx:xx Time xx:xx	Date & Time Setup

10.3 CAUSE & EFFECT TABLE

ACTIONS (NEW) (See also Section 9.1)

Input Selection			
Input Type	Selection 1	Selection 2	Options
Point	Loop (1-4)	Address (1 to 250)	Alarm
Zone	Range (1 -250)	To (1-250)	General Alarm MCP Alarm Detector Alarm Multiple Point Alarm Fault
Loop	Range (1 – 4)	To (1-4)	General Alarm
Panel	-	-	General Alarm Multiple Point Alarm Multiple Zone Alarm First Alarm

Output Selection						
Output Type	Selection 1	Selection 2	Local/ Remote	Delay	Output	*Tone
Point	Loop (1-4)	Address (1 to 250)	RMT/No/Yes (1-032)	Delay (000-999)	ON* OFF*	Alarm + Flash Alert + Flash Emergency + Flash Flasher Alarm Alert Emergency
Zone	Range (1 -250)	To (1-250)	RMT/No/Yes (1-032)	Delay (000-999)	Outputs ON Outputs OFF Sounders ON* Sounders OFF Relays ON Relays OFF	Alarm + Flash Alert + Flash Emergency + Flash Flasher Alarm Alert Emergency
Loop	Range (1 – 4)	To (1-4)	RMT/No/Yes (1-032)	Delay (000-999)	Outputs ON Outputs OFF Sounders ON* Sounders OFF Relays ON Relays OFF	Alarm + Flash Alert + Flash Emergency + Flash Flasher Alarm Alert Emergency

Panel	-	-	RMT/No/Yes (1-032)	Delay (000-999)	Outputs ON Outputs OFF Sounders ON* Sounders OFF Relays ON Relays OFF PCB Sounder One ON PCB Sounder One OFF PCB Sounder Two ON PCB Sounder Two OFF	Alarm + Flash Alert + Flash Emergency + Flash Flasher Alarm Alert Emergency
-------	---	---	--------------------	--------------------	--	---

Outputs Marked * have the tone selection option

ACTIONS (MODIFY)

For each ACTION (Cause & Effect) previously selected you can:
 Change Input Selection, i.e. Point / Zone / Loop / Panel etc.
 Change Output Selection, i.e. Point / Zone / Loop / Panel etc.
 Erase one or more previous action
 Exit to New / Modify

11- DISABLEMENTS

11.1 DISABLEMENT

To aid commissioning and assist routine maintenance checks, various functions of the Quatro fire alarm system can be disabled as described below.

11.2 ZONE DISABLEMENT

When a zone is disabled, the panel will not respond to any fault or fire signals it receives from DETECTORS from that zone.

This might be used if the system requires routine maintenance, and the user needs the rest of the system to continue running, but doesn't want spurious false alarms.

The panel will respond in the usual manner to any events in any non-disabled zones.

Any number of zones can be disabled, but it is good practice to only disable one zone at a time.

A zone can be disabled as follows:

- Turn the key switch clockwise to the Controls Enabled Position. The controls Active LED will light.
- Press any key followed by the Level 1 password (default 1111).
- Select **Zones** then **Disable**. Enter the zone(s) or range of zones to be disabled.
- Finally select Accept and then Exit.

When zones have been disabled, the General Disablement LED will be lit and also the zonal disablement LEDs (in one or both of the columns labelled FAULT DISABLE TEST). The zonal disablement LEDs only apply to zones 1 to 20.

When one or more zones have been disabled, the main screen on the LCD display changes from SYSTEM NORMAL to DISABLED ZONES, as shown.

In the example, line 2 indicates that a total of 9 zones have been disabled, and the 5th of these is shown on line 3. Zone 1 (Z001) has the text label FIRST FLOOR. The zone no. and text label for each disabled zone can be displayed by pressing



the control buttons F1 and F2 which correspond to [-], the previous disabled zone, and [+], the next disabled zone.

Alternatively, up to 10 disabled zones (without text labels) can be displayed in one screen as follows. Select any key followed by Level 1 password (default 1111), and then Zones followed by Show Disabled Zone. Zones are displayed in groups of 10, with the symbol X underneath a zone which has been disabled. The next group of 10 zones can be displayed by pressing the [+] symbol. The [-] symbol can be used to go back 10 zones.

To re-enable a disabled zone, repeat the same procedure used for disabling the zone, selecting Enable instead of Disable.

11.3 DEVICE DISABLEMENT

Rather than disable an entire zone, it is often useful to just disable one or more input devices or points (detector, call point, or interface) within a zone, especially if they are malfunctioning and likely to cause a false alarm or repeatedly indicate a fault.

To disable a device / point follow the same procedure as in Section 11.2 but selecting Point instead of Zone, followed by Disable.

Once a device is disabled, the panel ignores any alarms or faults generated by the device.

If all devices in a zone are disabled, the panel will indicate a zone disablement. If subsequently one or more devices are re-enabled then the zone disablement indication will be automatically cancelled.

When one or more points have been disabled, the main screen on the LCD display changes from SYSTEM NORMAL to DISABLED POINTS, as shown.

In the example, line 2 indicates that a total of 5 points have been disabled, and the 1st of these is shown on line 3. The 1st disabled device is an MCP which is located on loop 1 at address 97, with the text label "ENTRANCE". Each disabled point can be displayed by pressing the control buttons F1 and F2 which correspond to [-], the previous disabled point, and [+], the next disabled zone.

```

18/08/15 09:41
DISABLED POINTS 001/001
MCP (1.097) ENTRANCE
[ - ] [ + ]
    
```

Alternatively, up to 10 disabled points (without indicating device type or address) can be displayed on one screen as follows.

Select any key followed by Level 1 password (default 1111), and then **Points** followed by **Show Disabled Points**. The menu structure is then the same as for zone disablement.

To re-enable a disabled device, repeat the same procedure used for disabling the device, selecting Enable instead of Disable.

11.4 SOUNDER DISABLEMENT

On the Quatro Panel, all sounders can disable together through the User Menu. This affects the conventional sounder circuits, loop sounders, and any Platform (hidden) sounders. The user will also have the ability to disable sounders by zone, and can also choose which of the two conventional sounder circuits to disable, if required. All disabled sounders can become re-enabled though the same user menu.

When the sounders have been disabled, the Sounders Output Disablements LED will light up.

The LCD will show a list of all the sounders, showing that they are disabled.

```

28/04/15 12:08
DISABLED POINTS 002/005
SND (2.043) KITCHEN
[ - ] [ + ] [NEXT ]
    
```

It also shows both of the conventional sounder circuits are disabled on the screen on the LCD.

```

28/04/15 12:08
DISABLED PCB SOUNDER 001/002
SOUNDER ONE
[ - ] [ + ] [NEXT ]
    
```

11.5 RELAY DISABLEMENT

Relay outputs can also be disabled. These can either be addressable output units on any of the loops or a PCB output relay (ALARM or FAULT).

11.6 DISABLE BUZZER

To disable the internal panel buzzer while carrying out commissioning or maintenance then it can be done by the following:

- Enter the Installer menu (password 2222).
- Select 'General' and press the **ENTER** key.
- Scroll down to 'Disable Buzzer' using the directional keys, and press the **ENTER** key.
- Change the mode from 'Enable' to 'Disable' and press **F1** to accept.
- The internal buzzer should now be disabled, and the General Disablement LED should be lit. The buzzer can be re-enabled through the same route and should be done after testing/commissioning has been complete.

12- TEST MODE

12.1 WHY USE TEST MODE

To aid commissioning and assist routine maintenance check, a non-latching 'one man test' facility is available.

When a detector, manual call point or input unit is triggered on any zone in Test, the Alarm sounders operate for approximately 10 seconds on and then switch off. The triggered device is automatically reset. The panel will enter the fire condition and indicate the address of the fire. The panel automatically resets from the fire condition at the same time as the triggered device, but the LCD indication remains until the panel is manually reset.

If the device is still in the fire condition, e.g. MCP still activated or the analogue value of a detector still above the alarm threshold, the device will be triggered again and the Alarm sounders will operate for a further 10 seconds.

If an Alarm occurs on a zone that is not programmed to test, the Fire Alarm Panel will continue to operate as normal.

12.2 TO PROGRAMME ZONE IN TEST MODE

Turn the key switch clockwise to the Controls Enabled Position. The controls Active LED will light.

Press any key followed by the Level 1 password (default1111). Select Zones then Test.

The LCD displays the following:

Enter the range of zones to be put in to test mode. Change **[No]** to **[Yes]** if you require the Alarm sounders to operate as described in Section 14.1. If the Sounders are not enabled, a zone of devices can be tested silently. All of the events in 14.1 will occur apart from the sounders turning on and off again after 10 seconds.

```
TEST ZONE
RANGE : <001>          TO          : [001]
ENABLE SOUNDER : [NO ]
[Accept]                                [Exit ]
```

Press **[Accept]**. Note that this is the "SELECT ZONES TO TEST" screen. It is possible to select more than one zone or range of zones to test. So if ENABLE SOUNDER has been changed to **[Yes]**, the panel registers that those zones will be tested with sounder activation, and then clears the screen ready for the next entry. (I.e. the screen will revert to Zone <001> to <001> Enable sounders **[No]** when **[Accept]** is selected.) Finally select **[Exit]** to leave the Test Zone screen.

NOTE: When Enable Sounders is selected for test mode, the panel only operates the sounders in the zone that gives the alarm test.

When one or more zones are in test mode, the main screen on the LCD display will change from SYSTEM NORMAL to ZONES IN TEST, as shown.

In the example, line 2 indicates that a total of 2 zones have been disabled, and the 1st of these is shown on line 3. Zone 3 (Z003) has the text label THIRD FLOOR. The zone no. and text label for each disabled zone can be displayed by

```
28/04/15 12:20
ZONES IN TEST          001/002
Z003 - THIRD FLOOR
```

pressing the control buttons F1 and F2 which correspond to [-], the previous disabled zone, and [+], the next disabled zone.

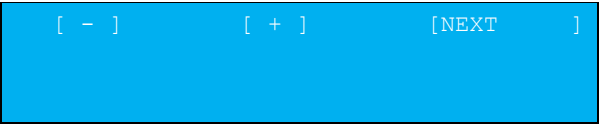

NOTE that if a fault condition or more than one of the disablement or test conditions described in sections 13 and 14 are present, then the condition displayed on the main screen is dependent on the following order of priority:

- FAULT CONDITION (highest priority)
- DISABLED ZONES
- DISABLED POINTS
- DISABLED PCB SOUNDER
- ZONES IN TEST (lowest priority)

The control button F4 (labelled [NEXT]) can be used to scroll between these conditions.

13- FAULT FINDING

13.1 LOOP CONTENTS FAULT FINDING

If the loop contents are different to what was expected, then there two probable causes:

Two or more devices may have the same address setting. This is referred to as a DOUBLE ADDRESS FAULT. If this occurs all devices with the same address will answer at the same time. The panel will not be able to understand the answer it receives. To find devices with the same address:

Press any key followed by the Level 2 password (default 2222), select **Points** and then **Toggling LED**. Enter the address which has been set for 2 or more devices. This will cause the indicating LEDs for all devices with this address to flash. Old Call Points, Sounders and some I/O units will not be indicated as they have no panel controlled LED to light up.

An alternative method to find a double address is to AUTOSEARCH the loop and check through REPORTS to see if there is a DAD listed. This gives a TYPE LOOP REPORT, i.e. the total number of each device type found on the loop which was auto-searched. Next by selecting ADDRESSES (button F3), the device type is displayed at each address from 1 to 250 (in groups of 10). Where there is no device present at an address, a blank replaces the device type. A double address is indicated by DAD.

There may be some reversed connections to devices (they are polarity sensitive). The positive core of the loop should be connected to the L2 terminals of the Fyreve MKII detector base, and the negative core to the L1IN terminals in the base. Other devices will have their polarity marked accordingly in their bases.

13.2 ZONE FAULTS

There are several reasons for the zone fault LED to light:

```
FAULT      0013/0021    30/06/09 13:47
LOOP       1           OPEN LOOP (+)
```

There is a cable break, or short circuit to devices on the loop.

```
FAULT      0007/0021    30/06/09 10:45
MKII-AOP   (2.087)     REMOVED
TEXT      : Kitchen
```

A device has been removed from the loop.

```
FAULT      0014/002    30/06/09 13:28
MKII-AHF   (1.002)     Double Address
TEXT      : Room 104
```

There is a Double Address on this loop.

```

FAULT      0015/0021      30/06/09  09:41
MKII-AHR   (1.4.24)  W TYPE
TEXT : Store Room

```

A device has been changed for one of a different type.

```

FAULT      0004/0021      30/06/09  16:59
ZAZM-M    (4.014)  FAULT
TEXT : Building Unit 6

```

A device in that zone is communicating a fault condition to the panel with its analogue value. A value that is 8 or less is usually a fault condition. (This could be a zone monitor reporting a fault in its zone wiring, for example.)

13.3 FALSE ALARMS

If your panel is giving out false alarms, it will most of the time be caused by a fault in the detector and not the panel itself. It is more common to have optical detectors give false alarms rather than heat detectors or call points. If you have a false alarm from an optical detector then you should check the following:

- ⤴ Check that detector is free of dust or any other contaminants. Clean out with compressed air if needed.
- ⤴ Check the device status (see 11.8), for analogue value for detectors, V is usually about 72 for clean air and 160 during alarm.
- ⤴ Check that the detector hasn't been installed in an area that creates a lot of carbon dioxide or steam that can trigger optical detectors. E.g. indoor car parks or shower rooms.
- ⤴ If a spare detector head is available, swap it with the one creating the false alarm. If the problem does not return, then you will know that it is the head that is the issue, and it will require either cleaning or replacing.

13.4 SUPPLY FAULTS

LOSS OF BATTERY POWER OR LOW BATTERY VOLTAGE

- ⤴ Check battery fuse.
- ⤴ Check that battery connections are secure.
- ⤴ Check battery voltage (should be around 26-27V).
- ⤴ Check that the two batteries are connected in SERIES (to give double the voltage of 1 battery on its own).
- ⤴ Check the charger fuse.

LOSS OF MAINS POWER

- ⤴ Check mains fuse.
- ⤴ Check that main power is present.
- ⤴ Check charger fuse.

LOSS OF BATTERY CHARGER

- ⤴ Check charger fuse.

HIGH INTERNAL RESISTANCE OF BATTERY

- ⤴ Replace old batteries with new ones.

Other possible causes of supply faults are:-

- ⤴ Wrong Charging Voltage.

The charging voltage should be 27.6V off load at 22-24°C. If it has been altered, reset using potentiometer

- ⤴ Overcharged Batteries.

Remove the batteries and measure the voltage. If they are reading over 27.6 V then the batteries are overcharged. Try to

run the panel on batteries only for half an hour or so to try to discharge the batteries. If this doesn't solve the problem, replacement batteries will be required.

13.5 EARTH FAULTS

An EARTH fault indicates that something is shorting to earth (usually through the cable screen). Disconnect the earth screens one at a time to determine the problem line.

(Note: connecting other equipment, e.g. an oscilloscope or USB to the panel can give an earth fault)

The earth fault message will indicate if it is a Positive or Negative voltage shorting to earth.

DO NOT DISCONNECT THE MAINS EARTH CONNECTION. THIS WILL CAUSE A PROBLEM WITH THE PANELS OPERATION

13.6 SYSTEM FAULT

A system fault is an abnormal microprocessor running condition due to various unexpected phenomena.

This will result in the panel attempting to correct itself. Should this fault occur, the System Fault LED, General Fault LED, General Fault relay and internal fault buzzer will be constantly active. A system fault indication can be cleared by momentarily closing jumper link JP20 on the display card (to the right of the coin battery). If the fault does not clear please consult your distributor.

13.7 SOUNDER FAULTS

Faults on the two conventional sounder circuits (connected to the Terminations PCB) and addressable sounders (connected to the loops) are indicated on the LCD display. Conventional sounder circuit faults are also indicated by a flashing LED on the OUTPUT DISABLEMENTS / FAULTS section of the panel.

13.8 OUT OF SERVICE FAULTS

If the system is in a condition in which it is unable to detect a fire or sound the alarm, for example if a loop is being configured, this is indicated to the User by lighting the "Out of Service" LED.

13.9 NETWORK FAULTS

Token Lost – This normally means that a panel is become missing in the network. Check that there are no breaks in the network wiring, and that all network cards and panels are still running.

Topology Change – This will normally be caused by a break in the network wiring.

Controller Fault – This will be shown if the network does not have a panel set to controller via the node setup menu. A network must always have a designated Quatro panel assigned to be a controller.

14- EVENT LOGS

In order to maintain useful system information, the Premier Quatro uses 4 separate event logs. All events, except Tests, are stored in the general log which has a capacity of 4096 events. Alarm events and Fault events are also stored in the Alarm log and Fault log, respectively. The former log can hold up to 512 events, and the latter up to 1024 events. Using this method ensures that regardless of the most recent entries, the last 512 alarms and 1024 faults will always be available. Test events are stored in a separate 512 entry log.

Alarm Log (512):

The screen will show the event number, the total no. of alarms, the date, the time, the type of device that is in alarm, the address of the device in alarm, which loop that it is in, and its location (i.e. text label). A maximum of 512 alarm events can be stored. When the alarm log is full, the next alarm over-writes the first alarm event, and so on.

```
ALARM          <0097>/0512 01/07/15 12:34
MCP Alarm      (1.064)
TEXT          : Room 123
[ - ]         [ + ]                               [Exit ]
```

Faults Log (1024):

The screen will show the event number, the total no. of faults, the date, the time, the type of fault that has occurred, the address of the device in fault, which loop that it is in, and its location (i.e. text label). A maximum of 512 faults can be stored. When the fault log is full, the next fault will over-write the first stored fault, and so on.

```
FAULT          <0123>/0512 01/07/15 12:34
Ter-STD        (1.002)  REMOVED
TEXT   : Room 12C
[ - ]         [ + ]                [Exit ]
```

All types of faults are stored in this category. For a device fault the layout is almost identical to the Alarm log (see example). For a general fault, line 2 is simply a description of the fault, and there is no information on line 3. The size of the Fault log is 1024.

Test Log (512):

This category indicates events that occur to devices contained in zones which are in the test mode. The LCD display is identical to that of the Alarm log. 512 test events can be stored.

All Log (4096):

This category stores all Alarm and Fault events but not Test events. It has a capacity of 4096.

Note: The Event Logs (also known as Reports) can be accessed by the Level 1 password (default 1111) or the Level 2 password (default 2222). The only difference is that with the Level 2 password it is also possible to erase the entire contents of all 4 logs. This should **NOT** be done during the normal use of the panel.

If a printer is fitted, refer to section 7.1.8 on how to print logs.

15- STANDBY BATTERY REQUIREMENTS

15.1 PANEL & DEVICE CURRENT RATINGS

The Following Table shows the Quiescent, Fault & alarm currents of the main parts of a Premier QUATRO Fire Alarm System:

DEVICE	PRODUCT CODE	I (MA) QUIESCENT	I (MA) FAULT	I (MA) ALARM	MAX PER LOOP
Panels					
Premier Quatro 1 Loop Analogue Addr Fire Alarm Panel	QT/1	140	140	190	N/A
Premier Quatro 2 Loop Analogue Addr Fire Alarm Panel	QT/2	190	190	240	N/A
Premier Quatro 3 Loop Analogue Addr Fire Alarm Panel	QT/3	240	240	300	N/A
Premier Quatro 4 Loop Analogue Addr Fire Alarm Panel	QT/4	300	300	360	N/A
Detectors					
Fyreve MKII Addressable Optical Smoke Detector	MKII-AOP	0.5	N/A	5	250
Fyreve MKII Addressable Heat Detector	MKII-AHR	0.5	N/A	5	250
Fyreve MKII Fixed Temperature Heat Detector	MKII-AHF	0.5	N/A	5	250
Fyreve MKII Addressable Opto-Heat Detector	MKII-AOH	0.5	N/A	5	250
Call Points					
Zeta Addressable Manual Call Point	ZT-CP3/AD	0.45	N/A	2.3	250
Zeta Addressable Weatherproof Manual Call Point	ZT-CP3/AD/WP	0.45	N/A	2.3	250
Sounders & Flashers					
MKII Zeta Addressable Raptor Sounder	MKII-ZRAP	2.3	N/A	6.4	64
MKII Zeta Addressable Raptor Sounder Beacon	MKII-ZRAPB	2.3	N/A	20.3	20
Fyreve MKII Addressable Maxitone Sounder	MKII-AMT	0.65	N/A	7	32
Fyreve MKII Addressable Maxitone Sounder Flasher	MKII-AMTF	0.7	N/A	10.6	32
Fyreve MKII Addressable Maxitone Flasher	MKII-AMF	0.6	N/A	5.5	32
Fyreve MKII Addressable Miditytone Sounder	MKII-AMD	0.65	N/A	4.5	64
Fyreve MKII Addressable Miditytone Sounder Flasher	MKII-AMDSF	0.7	N/A	7.5	48
Fyreve MKII Addressable Miditytone Flasher	MKII-AMDF	0.65	N/A	5.5	48
Fyreve MKII Addressable Xtratone Sounder	MKII-AXT	0.65	N/A	4.5	64
Fyreve MKII Addressable Xtratone Sounder Beacon	MKII-AXTB	2.3	N/A	20.3	20
Fyreve MKII Addressable Xtratone Flasher	MKII-AXF	0.6	N/A	5.5	48
Sandwich Sounder Base	MKII-SSB	0.65	N/A	5.5	64
Remote Indicator LEDs					
MKII Addressable Remote LED Indicator (Wall)	MKII-ARL/W	0.5	N/A	5	32
MKII Addressable Remote LED Indicator (Ceiling)	MKII-ARL/C	0.5	N/A	5	32
Interfaces					
Zeta Fyreve MKII Input Unit	ZAI-MI	1.0	1.25	3.6	64
Zeta Fyreve MKII Input Output Unit	ZAIO-MI	1.0	1.25	2	64
Zeta Fyreve MKII Input Output Unit – mains switching	ZAIO-MI /230	1.5	2.9	4.6	16
Zeta Fyreve MKII Sounder Control Module	ZASC-MI	0.6	0.6	0.8	64
Zeta Fyreve MKII Zone Monitor Module	ZAZM-MI	3.5	1.0	13.2	16
Wireless Transponder with LCD	WF-TRA-LCD	12	12	12	4
Wireless Transponder without LCD	WF-TRA-BFP	12	12	12	4
Special Mini Modules – Beam Detector	SMM/B	1.1	N/A	12	16
Conventional Sounders Via 2 Sounder Circuits(450mA per Conv Circuit)					
Zeta Conventional Maxitone Sounder	ZMT/8	0	N/A	15	N/A
Zeta Conventional Miditytone Sounder	ZMD/8	0	N/A	15	N/A
Zeta Conventional Securetone Sounder	ZST/8	0	N/A	15	N/A
Zeta Conventional Megatone Sounder	ZIDC	0	N/A	200	N/A
Zeta Conventional Flasher	ZFL2RR	0	N/A	90	N/A
Zeta Conventional Sounder Flasher	ZLT/8RR	0	N/A	110	N/A
Zeta Conventional 6" Bells	ZTB6B/24	0	N/A	25	N/A
Zeta Conventional 8" Bells	ZTB8B	0	N/A	35	N/A
Conventional Detectors (via a Zone Monitor)					
Fyreve Conventional Optical Detector	FEO2000	0.06	N/A	25	N/A
Fyreve Conventional Heat Detector (A1R)	FEHR2000	0.04	N/A	25	N/A
Fyreve Conventional Heat Detector (CS)	FEFH2000	0.04	N/A	25	N/A
Misc. Items					
GSM COMMUNICATOR	GSM-COM	200	500	500	N/A

The Maximum per loop values given above are a guideline, based on the assumption that other devices on the loop do not cause the total loop current to exceed the loop limit of 500mA.

15.2 STANDBY BATTERY CALCULATION

In order to calculate the standby battery size required, the following formula can be used:-

$$\text{Battery Size (Standby time in Amp Hours)} = 1.25 \times [(T_{\text{ALM}} \times I_{\text{ALM}}) + (T_{\text{SBY}} \times (I_{\text{QP}} + I_{\text{QL}}))]$$

Where:

T_{ALM} = Maximum time in hours required for the alarm [$\frac{1}{2}$ hour is most common time]

I_{ALM} = Total Alarm Current in amps

$I_{\text{ALM-SND}}$ = Alarm Current of Sounders in amps

T_{SBY} = Standby time in hours for the system after mains failure [normally 24, 48 or 72 hr]

I_{QP} = Quiescent current in amps of control panel in fault condition [because of mains failure]

I_{AP} = Alarm current in amps of control panel

I_{QL} = Quiescent current in amps of all loop devices.

Typical Example:

A system comprises of a 1 Loop Quatro panel, with 80 Fyreve Extra Addressable Optical Smoke Detectors, 15 Zeta Addressable Manual Call Points, 20 Zeta Addressable Securetone 2 Sounders and the required standby is 24 hours. It will need to operate in alarm for $\frac{1}{2}$ hour.

Calculate the battery size required.

$$T_{\text{ALM}} = 0.5 \text{ Hr}$$

$$I_{\text{ALM-SND}} = 20 \times 0.004 = 0.08\text{A}$$

$$T_{\text{SBY}} = 24 \text{ Hr}$$

$$I_{\text{QP}} = 0.20\text{A}$$

$$I_{\text{AP}} = 0.19\text{A}$$

$$I_{\text{QL}} = 80 \times 0.00044 + 15 \times 0.001 + 20 \times 0.0005 = 0.0602\text{A}$$

$$I_{\text{ALM}} = I_{\text{ALM-SND}} + I_{\text{AP}} + I_{\text{QL}} = 0.08 + 0.19 + 0.0602 = 0.3302$$

Therefore using the equation:

$$\text{Battery Size (Standby time in Amp Hours)} = 1.25 \times [(T_{\text{ALM}} \times I_{\text{ALM}}) + (T_{\text{SBY}} \times (I_{\text{QP}} + I_{\text{QL}}))]$$

$$\text{Battery Size (Standby time in Amp Hours)} = 1.25 \times [(0.5 \times 0.33) + (24 \times (0.20 + 0.06))]$$

$$\text{Battery Size (Standby time in Amp Hours)} = 1.25 \times [(0.5 \times 0.33) + (24 \times 0.26)]$$

$$\text{Battery Size (Standby time in Amp Hours)} = 1.25 \times [0.165 + 6.24]$$

$$\text{Battery Size (Standby time in Amp Hours)} = 1.25 \times 6.405$$

$$\text{Battery Size (Standby time in Amp Hours)} = 8.01 \text{ Amp Hours}$$

For a system like this, 2 x 12V sealed lead acid batteries must be used each with a capacity greater than 8.01 Ah. For example, 12Ah

16- QUATRO PANELS AVAILABLE

MODEL	PRODUCT CODE
Premier Quatro 1 Loop Analogue Addressable Fire Alarm Panel	QT/1
Premier Quatro 2 Loop Analogue Addressable Fire Alarm Panel	QT/2
Premier Quatro 3 Loop Analogue Addressable Fire Alarm Panel	QT/3
Premier Quatro 4 Loop Analogue Addressable Fire Alarm Panel	QT/4
Premier Quatro 4-8 Loop Analogue Addressable Fire Alarm Panel	QT/4-8
Premier Quatro 5-8 Loop Analogue Addressable Fire Alarm Panel	QT/5-8
Premier Quatro 6-8 Loop Analogue Addressable Fire Alarm Panel	QT/6-8
Premier Quatro 7-8 Loop Analogue Addressable Fire Alarm Panel	QT/7-8
Premier Quatro 8-8 Loop Analogue Addressable Fire Alarm Panel	QT/8-8
Premier Quatro 1 Loop Analogue Addressable Fire Alarm Panel W/ Printer	QT/1P
Premier Quatro 2 Loop Analogue Addressable Fire Alarm Panel W/ Printer	QT/2P
Premier Quatro 3 Loop Analogue Addressable Fire Alarm Panel W/ Printer	QT/3P
Premier Quatro 4 Loop Analogue Addressable Fire Alarm Panel W/ Printer	QT/4P
Premier Quatro 4-8 Loop Analogue Addressable Fire Alarm Panel W/ Printer	QT/4-8P
Premier Quatro 5-8 Loop Analogue Addressable Fire Alarm Panel W/ Printer	QT/5-8P
Premier Quatro 6-8 Loop Analogue Addressable Fire Alarm Panel W/ Printer	QT/6-8P
Premier Quatro 7-8 Loop Analogue Addressable Fire Alarm Panel W/ Printer	QT/7-8P
Premier Quatro 8-8 Loop Analogue Addressable Fire Alarm Panel W/ Printer	QT/8-8P
Premier Quatro 1 Loop Analogue Addressable Fire Alarm Panel W/ 120 Zone LEDS	QT/1/100Z
Premier Quatro 2 Loop Analogue Addressable Fire Alarm Panel W/ 120 Zone LEDS	QT/2/100Z
Premier Quatro 3 Loop Analogue Addressable Fire Alarm Panel W/ 120 Zone LEDS	QT/3/100Z
Premier Quatro 4 Loop Analogue Addressable Fire Alarm Panel W/ 120 Zone LEDS	QT/4/100Z
Premier Quatro 4-8 Loop Analogue Addressable Fire Alarm Panel W/ 120 Zone LEDS	QT/4-8/100Z
Premier Quatro 5-8 Loop Analogue Addressable Fire Alarm Panel W/ 120 Zone LEDS	QT/5-8/100Z
Premier Quatro 6-8 Loop Analogue Addressable Fire Alarm Panel W/ 120 Zone LEDS	QT/6-8/100Z
Premier Quatro 7-8 Loop Analogue Addressable Fire Alarm Panel W/ 120 Zone LEDS	QT/7-8/100Z
Premier Quatro 8-8 Loop Analogue Addressable Fire Alarm Panel W/ 120 Zone LEDS	QT/8-8/100Z
Premier Quatro 1 Loop Analogue Addressable Fire Alarm Panel In Stainless Steel	QT/1/SS
Premier Quatro 2 Loop Analogue Addressable Fire Alarm Panel In Stainless Steel	QT/2/SS
Premier Quatro 3 Loop Analogue Addressable Fire Alarm Panel In Stainless Steel	QT/3/SS
Premier Quatro 4 Loop Analogue Addressable Fire Alarm Panel In Stainless Steel	QT/4/SS
Premier Quatro 1 Loop Analogue Addressable Fire Alarm Panel In Stainless Steel W/ Printer	QT/1P/SS
Premier Quatro 2 Loop Analogue Addressable Fire Alarm Panel In Stainless Steel W/ Printer	QT/2P/SS
Premier Quatro 3 Loop Analogue Addressable Fire Alarm Panel In Stainless Steel W/ Printer	QT/3P/SS
Premier Quatro 4 Loop Analogue Addressable Fire Alarm Panel In Stainless Steel W/ Printer	QT/4P/SS
Premier Quatro 1 Loop Analogue Addressable Fire Alarm Panel In Stainless Steel W/ 120 Zone LEDS	QT/1/100Z/SS
Premier Quatro 2 Loop Analogue Addressable Fire Alarm Panel In Stainless Steel W/ 120 Zone LEDS	QT/2/100Z/SS
Premier Quatro 3 Loop Analogue Addressable Fire Alarm Panel In Stainless Steel W/ 120 Zone LEDS	QT/3/100Z/SS
Premier Quatro 4 Loop Analogue Addressable Fire Alarm Panel In Stainless Steel W/ 120 Zone LEDS	QT/4/100Z/SS
Premier Quatro 1 Loop Analogue Addressable Fire Alarm Panel In Stainless Steel W/ 120 Zone LEDS & Printer	QT/1P/100Z/SS
Premier Quatro 2 Loop Analogue Addressable Fire Alarm Panel In Stainless Steel W/ 120 Zone LEDS & Printer	QT/2P/100Z/SS
Premier Quatro 3 Loop Analogue Addressable Fire Alarm Panel In Stainless Steel W/ 120 Zone LEDS & Printer	QT/3P/100Z/SS
Premier Quatro 4 Loop Analogue Addressable Fire Alarm Panel In Stainless Steel W/ 120 Zone LEDS & Printer	QT/4P/100Z/SS
Premier Quatro 1 Loop Analogue Addressable Fire Alarm Panel W/ 120 Zone LEDS & Printer	QT/1P/100Z
Premier Quatro 2 Loop Analogue Addressable Fire Alarm Panel W/ 120 Zone LEDS & Printer	QT/2P/100Z
Premier Quatro 3 Loop Analogue Addressable Fire Alarm Panel W/ 120 Zone LEDS & Printer	QT/3P/100Z
Premier Quatro 4 Loop Analogue Addressable Fire Alarm Panel W/ 120 Zone LEDS & Printer	QT/4P/100Z
Premier Quatro 4-8 Loop Analogue Addressable Fire Alarm Panel W/ 120 Zone LEDS & Printer	QT/4-8P/100Z
Premier Quatro 5-8 Loop Analogue Addressable Fire Alarm Panel W/ 120 Zone LEDS & Printer	QT/5-8P/100Z
Premier Quatro 6-8 Loop Analogue Addressable Fire Alarm Panel W/ 120 Zone LEDS & Printer	QT/6-8P/100Z
Premier Quatro 7-8 Loop Analogue Addressable Fire Alarm Panel W/ 120 Zone LEDS & Printer	QT/7-8P/100Z
Premier Quatro 8-8 Loop Analogue Addressable Fire Alarm Panel W/ 120 Zone LEDS & Printer	QT/8-8P/100Z
Premier Quatro 1 Loop Command Center	QT/1/CC
Premier Quatro 2 Loop Command Center	QT/2/CC
Premier Quatro 3 Loop Command Center	QT/3/CC
Premier Quatro 4 Loop Command Center	QT/4/CC
Premier Quatro 4-8 Loop Command Center	QT/4-8/CC
Premier Quatro 5-8 Loop Command Center	QT/5-8/CC
Premier Quatro 6-8 Loop Command Center	QT/6-8/CC
Premier Quatro 7-8 Loop Command Center	QT/7-8/CC
Premier Quatro 8-8 Loop Command Center	QT/8-8/CC

INSTALLATION MANUAL MODIFICATION HISTORY

Issue	Date	Changes
1.26	17/1/2011	Version before Modification history page added (Typo in date – should be 17/1/2012)
1.27	23/4/2012	Amended PSE Output voltage range (p50) Amended CIE input voltage range (p50) Reworded Port list (p50)
1.28	26/4/2012	Removed all references to 250 Zones
1.29	14/6/2012	Added Sounder delay turn on/turn off note Corrected Loop Earth wire connection diagram. Corrected Mains voltage to 230V
1.30	13/7/2012	Updated Images to Grey Label Fixed document formatting issues
1.31	25/7/2012	Added Cable Type Info Added battery type information Added CE Declaration Box Updated Device wiring Information
1.32	19/11/2012	Corrected typo in Test mode Section 14.2 (Mentioned 13.1 – should have been 14.1) Added better explanation of selecting test mode with sounders.
1.33	14/1/2013	Corrected EOL in sounder connection drawings from 10K to 4k7
1.34	14/8/2015	Removed Standard Protocol Added Loop Management (Loop) Added Alarm Tone Setup (Loop) Added Flasher Operation (Loop) Added Engineering (Loop) Added Disable by Zone (Sounders) Added Enable by Zone (Sounders) Added PCB Outputs (Sounders) Added LED Setup (Points) Added New Logic (Actions) Added Modify Logic (Actions) Added Class Change (Actions) Added Disable Relays (Actions) Added Disable Outputs (Actions) Added Disable Buzzer (General) Added Enable USB Config (General) Added Day-Night Mode Added Version (Network) Added View Current Topology (Network) Added Shared Zones (Network) Added Real Time (Printer) Added Print Log (Printer) Added Modbus
1.35	14/12/2016	Added page numbers to contents page Fixed chapter numbering issues
1.36	25/5/2017	Added section 4.8 pre commissioning checklist Fixed chapter numbering issues Changes to header



0359

Zeta Alarm Systems,
72-78 Morfa Road, Swansea SA1 2EN

12

0359-CPD-0139

EN54-2:1997+A1:2002 + A2: 2006

EN54-4:1997+A1:2002 + A2: 2006

Control and indicating equipment for fire detection and fire
alarm systems for buildings

Premier Quatro
QT/1,QT/2,QT/3,QT/4

Provided options:

Output to fire alarm devices
Delays to outputs
Fault signals from points
Disabling of addressable points
Test condition

Other Technical Data: See Doc: "Premier Quatro Product file"
held by the manufacturer